



**sofis**

valve operation

## SFC interlocks



*'With a track record, which expands over three decades, our customers return to us, time after time.'*

Using Smith Flow Control's (SFC) interlock solutions, we help you reduce the scope for operator error and ensure safe and continuous operation of your plant.

## **About process interlocking**

Although accidents in process industries are fairly infrequent, when they do happen, they tend to be serious in scale and nature. Operator mistakes and failure to follow procedures or bypassing steps, carry great risks. The start-up, shut-down and shift hand-overs are all examples of where one small slip in due diligence, can have severe consequences.

To help reduce your risks, we offer a way of ensuring a safe sequence of valve operation.

We custom engineer a solution that locks in a set position, your manual valves or any other process safety related equipment until a time when it is safe to operate them. A predetermined logic ensures that only the right valve is opened at the right time using linear coded keys. Your interlocks are built with bespoke code bars in them. These code bars will only ever accept their designated interlock key.

*'Innovators of the coded-card linear-key concept.'*



# Guiding you through safe work procedures step by step

Human error is removed as when using our valve interlocks, your operators are compelled to follow a safe sequence of valve operations - There are no short-cuts.

## Multiple benefits from using our interlocks

- You create a safer working environment for your team of operators and those around them.
- You promote adherence to safe working procedures and reduce downtime.
- You protect the environment through minimising risk.
- You reduce potential costs by preventing product loss and reputational risk.



# QL valve interlocks

QL valve interlocks are designed to suit all types of lever operated and quarter-turn valves, including ball, butterfly, and plug valves. You can mount them without any modification to your host valve.

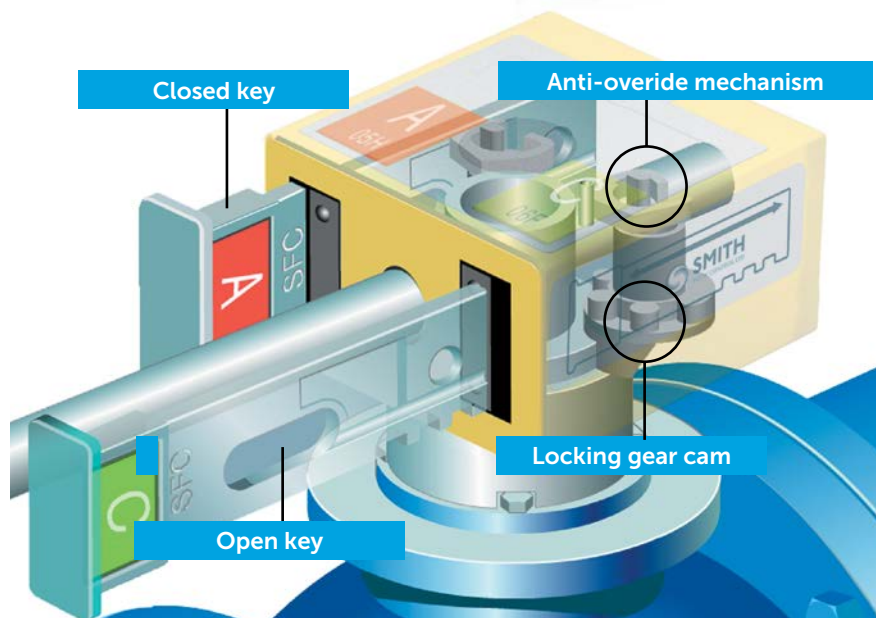
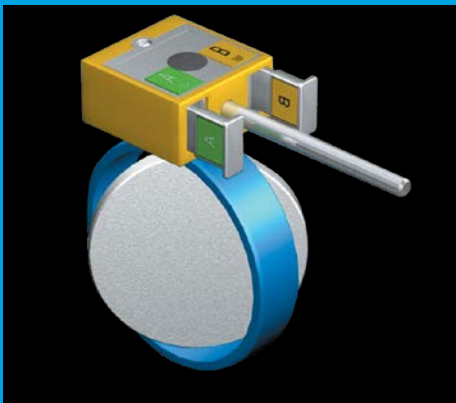
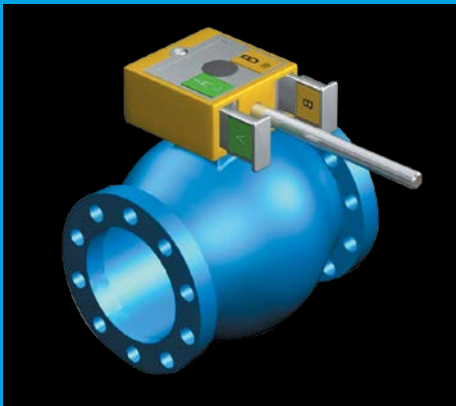
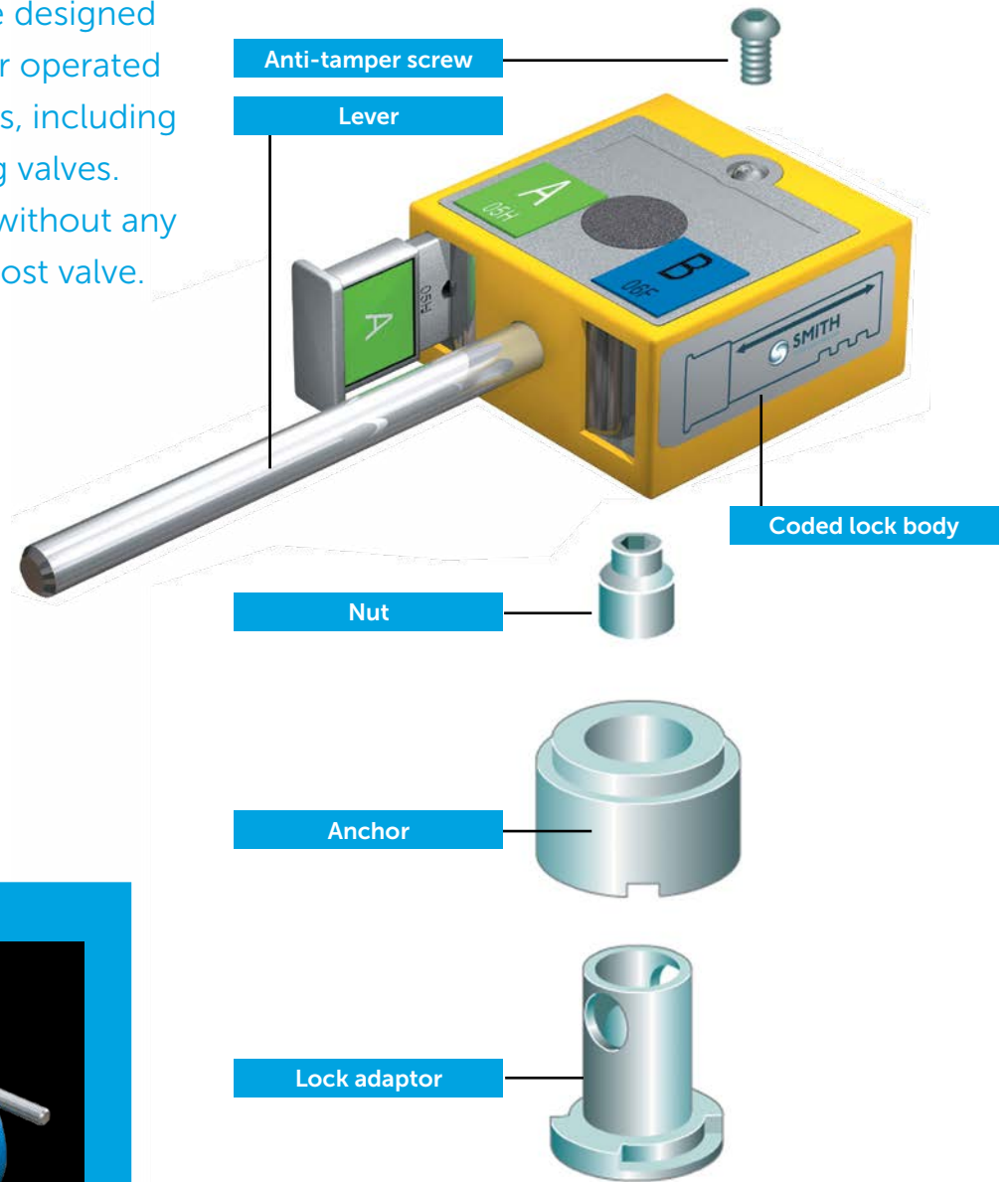

# GL valve interlocks

GL valve interlocks are designed to suit all types of handwheel operated valves, including Gate, Globe and Gear-operated valves. You can mount them without any modification to your host valve.

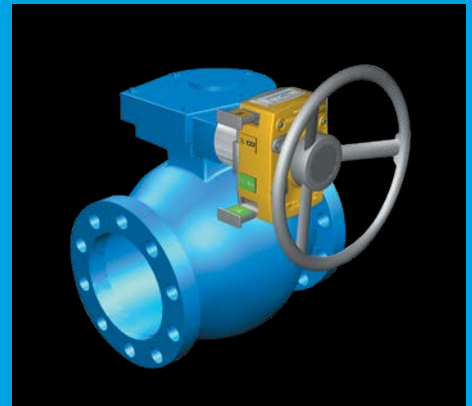
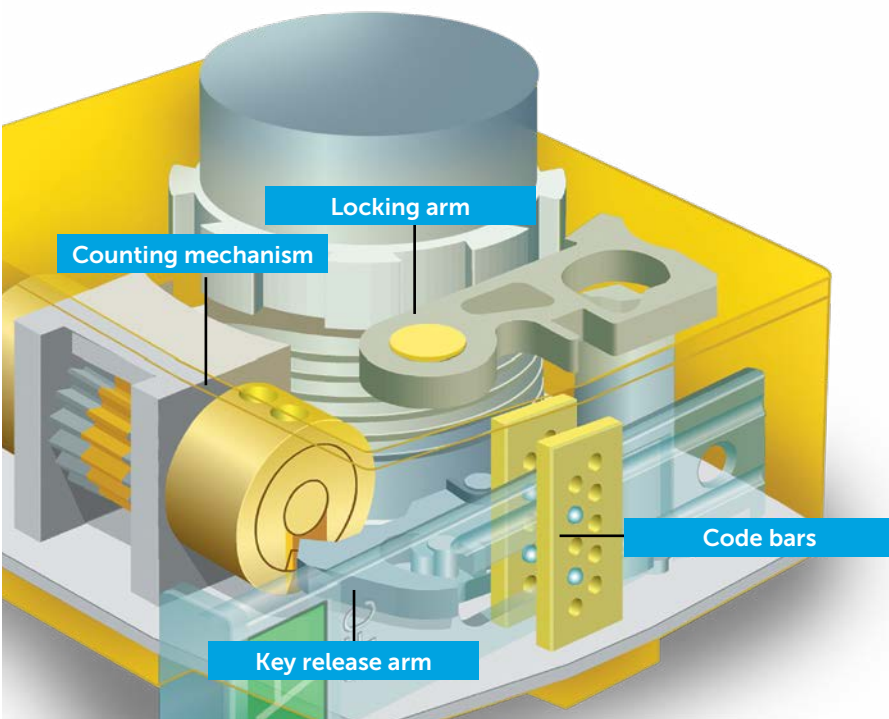
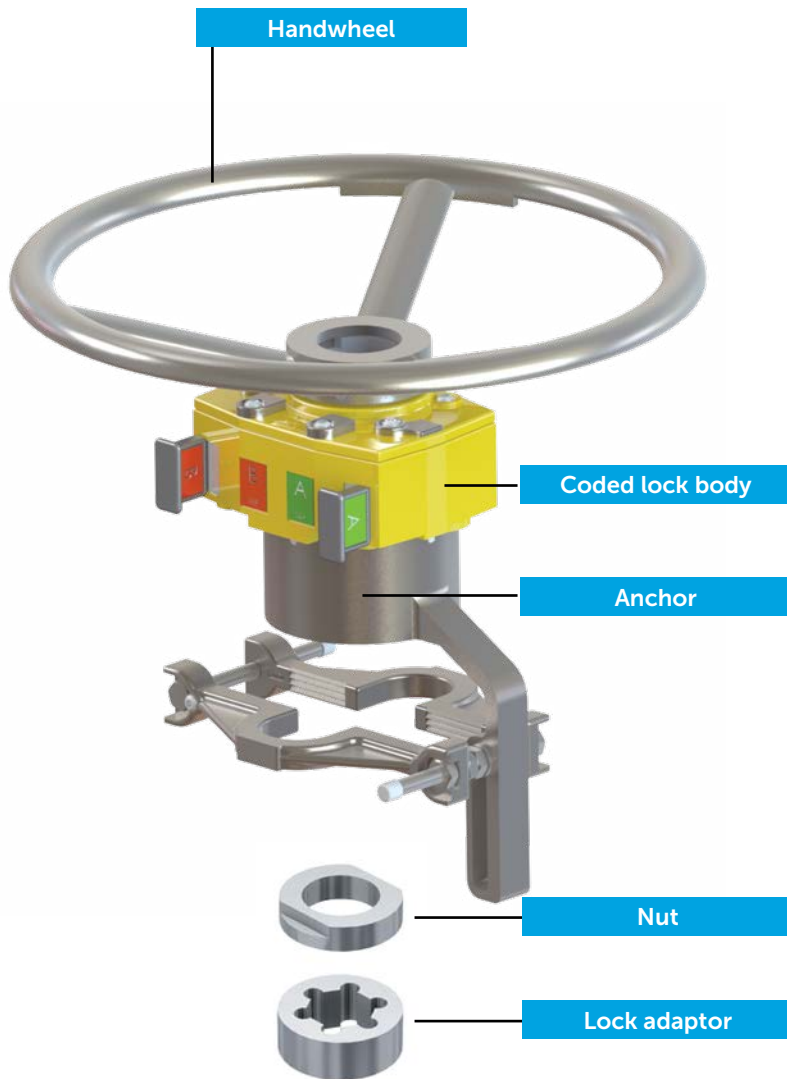

# Vessels & closures

Access a pressure vessel is a potentially hazardous exercise. Opening a vessel door when there is residual pressure, liquids or gases in your pipelines can cause you serious harm. Examples of potential hazards include pig traps, slug catchers and filter housings.

Using our DL interlock, you can lock closed your vessel door. You will only ever be able to open it, when it is proven safe to do so. As an example, the operating key is held in a control room or retained (trapped) in another valve, forming part of an interlocking sequence. The key to open the door is only released when safe conditions prevail.

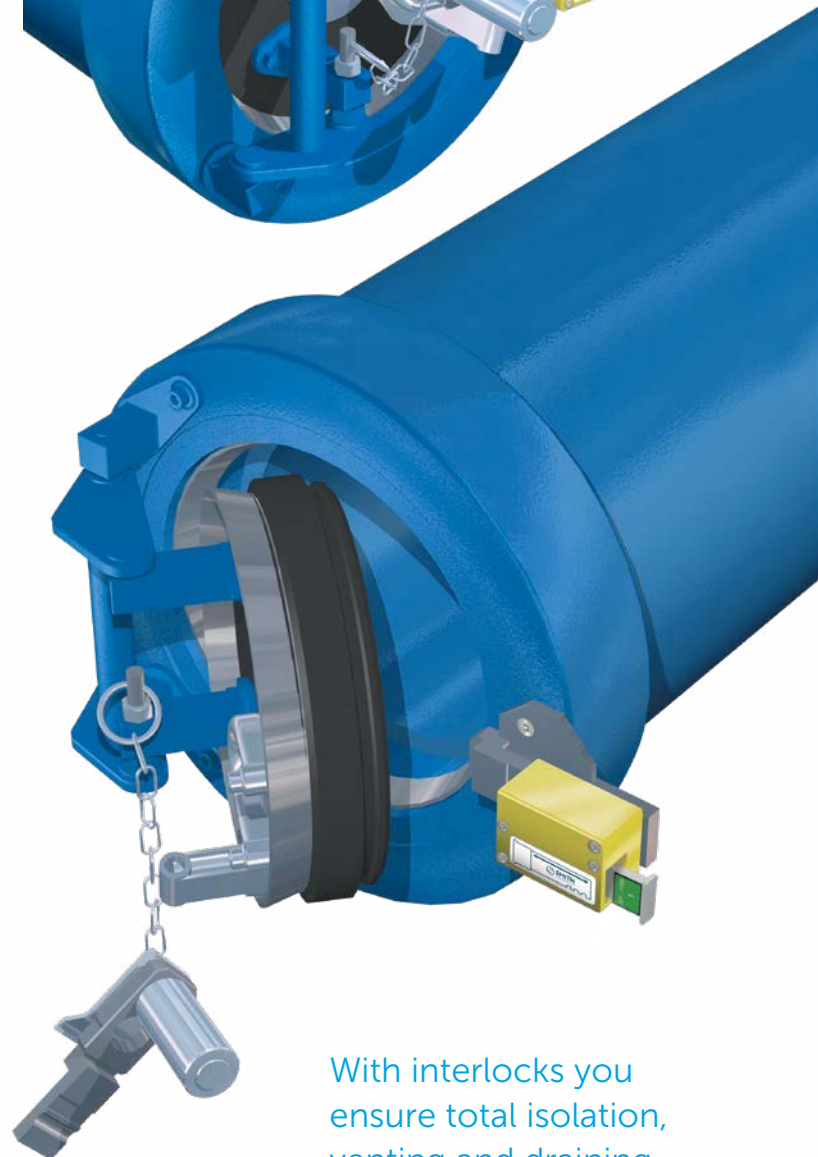

## Preventing loss of containment and protecting your operators

Our DL interlock is designed to fit to any type of closure. Designed to interface with the bleed function of your closure door, the bleed screw cannot be removed until the designated key has been inserted to unlock the DL interlock.

This key is usually obtained after opening and locking of your vent valve and can incorporate all other vessel functions - draining, purging or flushing. This guarantees safe operation of a potentiality hazardous exercise.

With interlocks you ensure total isolation, venting and draining before your operators can open your vessel door.

# Actuated (motorised) valves

Where you have both power operated and manually operated valves, you can integrate them using interlocks. Typical examples of this include pig launcher/receiver systems, scraper traps and sand filter systems.

Using our MOV interlocks, you can fully integrate your actuators into valve interlock operating procedures and sequences.

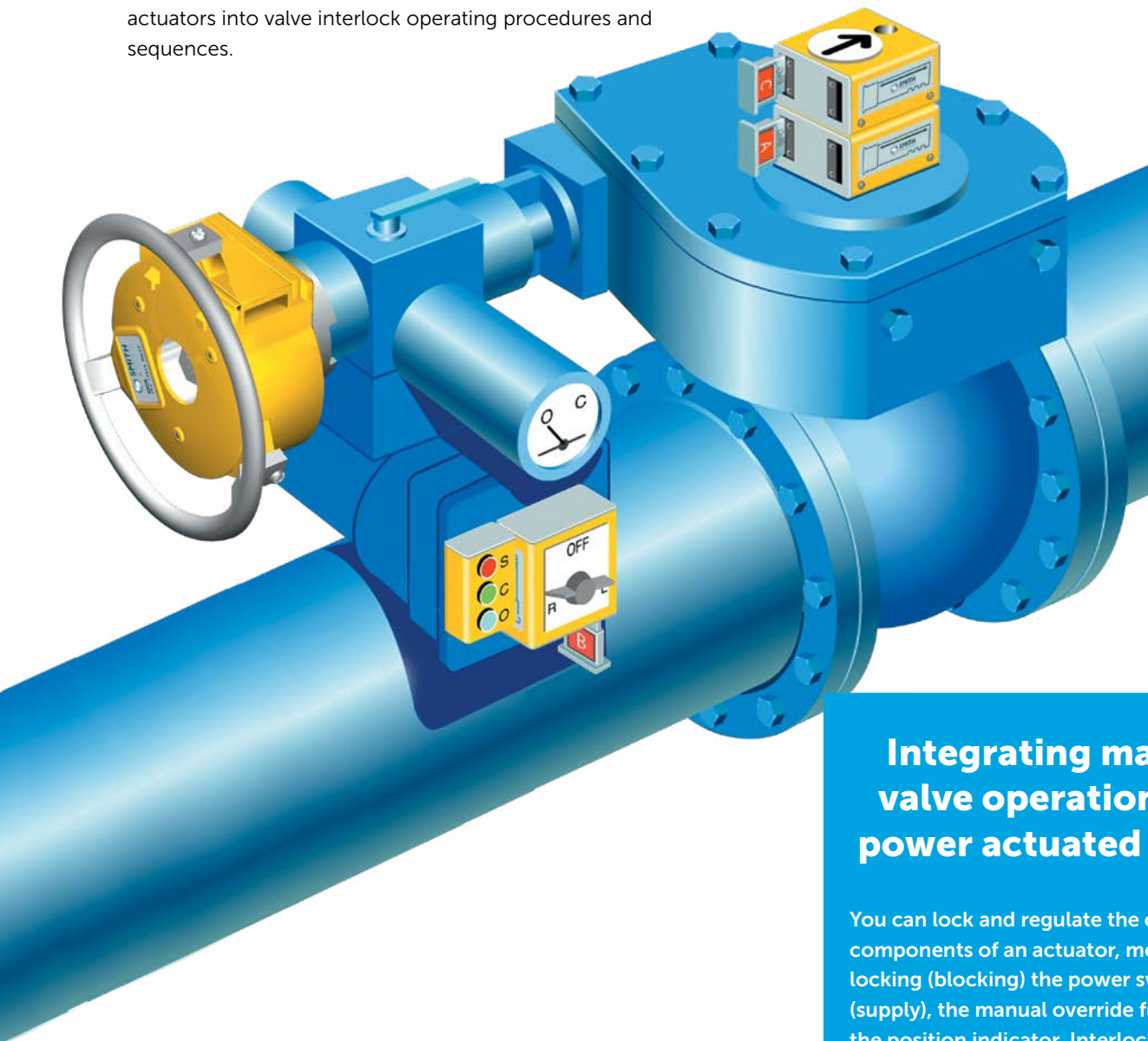

Using our interlocking solution, you can incorporate your MOVs into an interlocking sequence of manually operated valves.

## Integrating manual valve operation into power actuated valves

You can lock and regulate the operation of components of an actuator, mechanically locking (blocking) the power switch (supply), the manual override function and the position indicator. Interlock keys are exchanged between the different locked components of the actuator. You can prove the mechanical valve status, independent of a DCS management system.

They are designed to suit all types of actuators, from multi-turn, motorised gate valves to hydraulic and pneumatic actuators.

# Key cabinets

With all valve interlocks, we recommend an effective storage system for your keys. This will help you to prevent unauthorised and inadvertent use of interlocked valves and other important process equipment.



Simply by looking at the keys in your cabinet, you gain an overview of the status of your interlocked process systems. A cabinet with all its keys stored, indicates normal operation. Work is in progress when a key is missing from the cabinet.

We offer holster and horizontal key cabinets, to accommodate different quantities of interlock keys.

## Giving you more from your valve interlock installations

Our key storage cabinets provide an additional layer of control over your operators and process equipment.

For further upgrades and to gain greater data and insight from your interlock installations, a range of key management systems are also available.







## ATL (Anti tamper lock)

You may require a simple to use locking device to prevent accidental or unauthorised operation. The ATL has been developed to fit directly on to your valves in place of the normal handwheel or operating lever, with minimal machining. This can be easily done at site.

Only a designated key allows operation of your valves. Depending on your requirements, the valve can be operated to any position. Once the key has been removed, the unit freewheels and prevents further valve operation.



## Expanded chainlock

The expanded chainlock is the first of two security solutions used for commissioning and low risk procedures, where you do not need sequential control. It is a simple security solution, which combines features of a padlock and interlock. Flag style colour aware keys enables incorporation into interlock key exchange systems.



## Car seal

Our second solution, ideally suited for commissioning is a once only method of securing of your manual valves, switches and enclosures. A simple 'break-away' screw secures the seal in place. You can only remove it by cutting the seal cable.

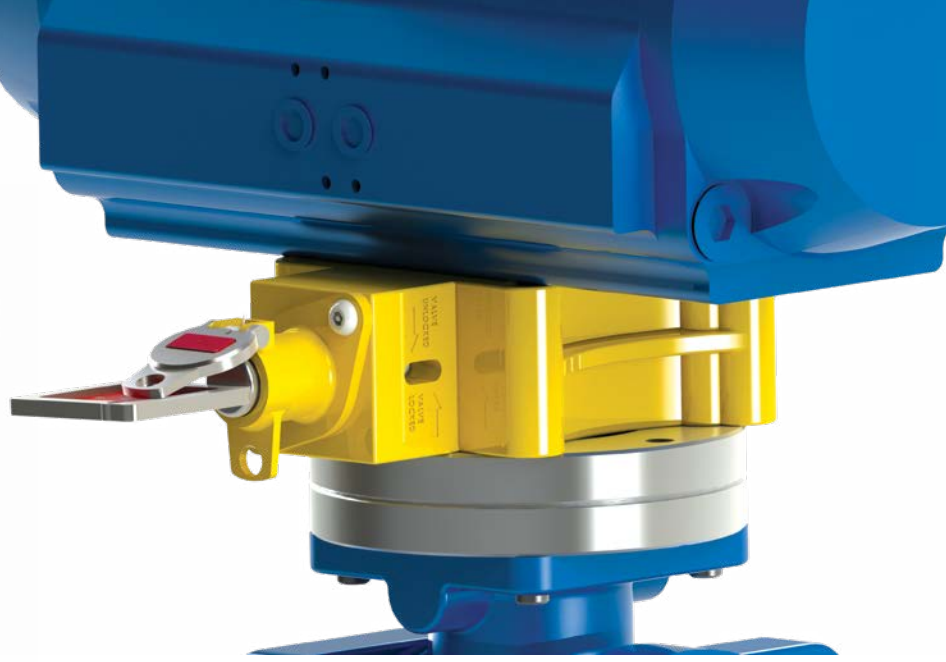

## IML intermediate lock

With the IML intermediate lock fitted, you can mechanically control any ISO pattern actuator. During maintenance, the command system managing your valves may need to be suspended. Your valves must be set to their fail-safe position and disabled both

remotely and locally, so that work can proceed safely. Our IML uses an interlock key to lock your actuator in the desired open or closed position to prevent the valve from turning.

## ComKey (Commissioning key) Dust plug

To commission a system, you will need to operate the valves and their keys as you would under normal conditions. A ComKey enables you to freely operate your interlocked valves. Once the key is removed after all testing/commissioning tasks are completed, it cannot be re-used. The interlock will only now accept its dedicated coded key for normal operations. The ComKey removes your need for commissioning master keys, saves time and simplifies your processes.

When using interlocks, you will want to reduce the risk of dust and dirt ingress. You can better protect your interlocks using dust plugs, which seal off the key entry points. When you remove an interlock key, you can insert a dust plug to help protect your valve interlocks and keep them in good condition.

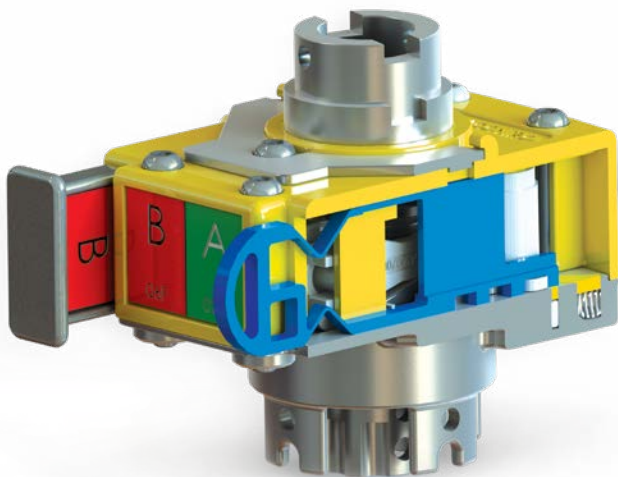



## SCU (Sequence control unit)

The SCU is designed to enable you to complete complex variations in your operating sequences. An example of this is on launcher/receiver systems. In normal conditions, all interlock keys in the unit are trapped. It is only when you insert an initiating key and turn the knob (at top of unit), the next process key is released. You can see step by step, which key to remove using the visual indicator. This eliminates any potential for error brought about through bypassing critical process steps.

## Explosion proof interlock switch

The Atex certified switch is used when you need to mechanically interlock an electrically operated device. Our valve interlock is fitted to your control switch. A single or dual key option will lock in the 'on', 'off' or both positions. Solenoid key release units are a valuable addition used around pig traps to receive a 'low pressure' signal to indicate that it is safe to open the vessel closure door.



## QL proximity switch

This Atex certified switch can be incorporated into all your valve interlocks where you need a signal to prove:

- Key entry or removal
- Valve open or closed, indicated by the removal of the interlock key and locked in that position

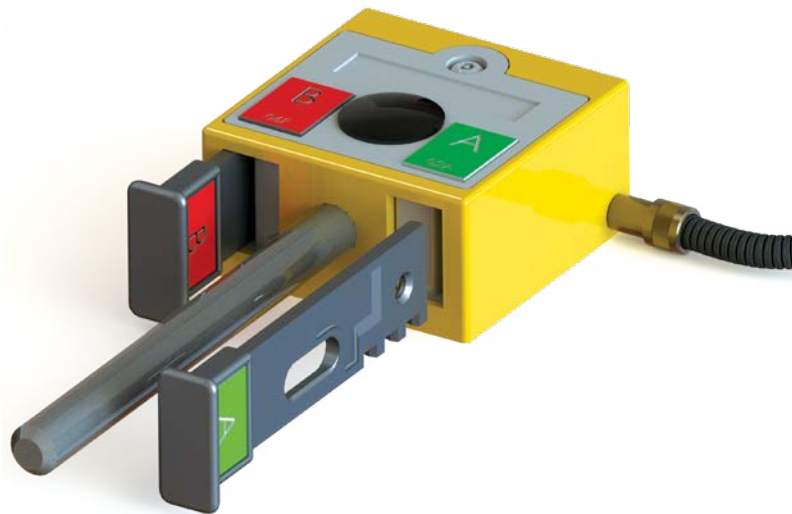

# Pressure relief valves

During maintenance of your live safety relief systems, you will need to maintain an open path to relief at all times. Using our interlocks, you will eliminate any pressure build up in your pipelines.



## PSV interlocking

Most pipeline installations will include a spare relief capacity, which enables you to complete your maintenance procedures, whilst continuous production takes place. This eliminates the need to isolate and shut down the whole process, which is a costly and time consuming process. However, when working a live plant, you will want to ensure that only one valve is closed at any one time.

Typically, twin or multiple safety relief valve systems are fitted with isolation block valves both upstream and downstream of each safety relief valve. Block valves isolating the spare relief valve must be opened before the ones set for maintenance are closed. Fitting a valve interlock to your upstream and downstream isolating valves on each safety relief valve, will ensure safety is maintained at all times.

# Pig launching and receiving

Pigging operations are inherently dangerous. Opening a pig trap closure while there is pressure in the barrel will shoot the pig out. Anything in its path, including you, will be taken out. Using our interlocks, you will only be able to open the pig trap door, when it is safe to do so and the pressure is removed.

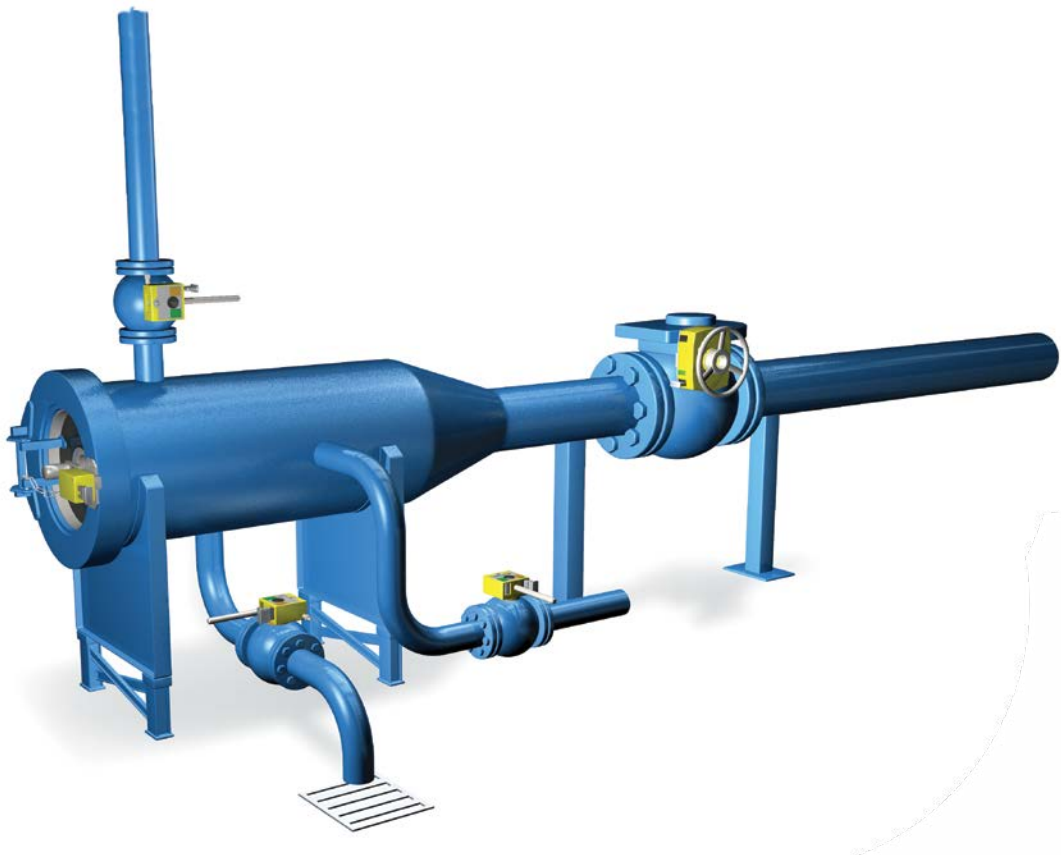

## Pig trap interlocking

Using our interlocks, you can safely control pig launching and retrieving procedures, no matter how complex the operation.

Our interlocks can be specified to ensure the minimum safety arrangement of interlocking the vessel vent valve with the pig trap door. This arrangement ensures your vessel vent valve is open before any attempt can be made to open the closure. When the vent valve is locked in the open position, a key coded in common with the pig trap door is released to enable you to open it safely. Using our interlocks, all critical valves can only be operated again, when the closure is fully closed and locked.



# Service Support

You want the right people with the right skills and resources at a time when you need them most. That is critical to efficient valve operations and getting your plant fully operational as quickly as possible.



Our team of highly trained and experienced site technicians are available to help you address your plant needs. We offer practical support to cover the following areas:

## Installation and commissioning

We ensure your equipment is installed and handed back over to you in the most efficient manner.

## Valve topwork measurements

We take detailed measurements from site to ensure that we have all the data we need and that there are no hold ups or delays.

## Emergency call out and repair

We can help you to get your systems back up and running with minimal downtime.

## Maintenance

We recommend regular maintenance of your equipment to keep your assets in good working condition.

## Stand by and turnaround services

We are responsive to your plant needs and can work with you in advance of your turnarounds to ensure a smooth process and any interlock issues are speedily resolved.

## Training

We develop and design training to suit your needs and to empower your operators with practical skills and knowledge.

*'Whatever your plant need, our site team are here to help you.'*

# Experience

Smith Flow Control's interlock solutions mitigate significant environmental and workplace risks by removing the 'human factor'. With our extensive track record, we retain the confidence of our customers by providing customised solutions that greatly enhance safety and efficiency.



**FLUOR**

ConocoPhillips



ExxonMobil



**KBR**



Smith Flow Control and Netherlocks have merged. We are Sofis, the leading valve operation specialists. With our combined expertise we offer smart integrated solutions to optimise valve operation. Our products help create a safer and more efficient working environment and are often regarded as the industry standard. We work closely with our customers and provide simple and reliable solutions.



#### Contact

For support:  
[support@sofisglobal.com](mailto:support@sofisglobal.com)  
For enquiries:  
[www.sofisglobal.com/contact](http://www.sofisglobal.com/contact)

#### Online

[www.sofisglobal.com](http://www.sofisglobal.com)  
YouTube: Sofis valve operation  
Facebook: @Sofisglobal  
Twitter: @Sofisglobal

#### Locations

Alphen aan den Rijn, Netherlands  
+31 172 471339  
Beijing, China  
+86 10 5879 7989  
Dubai, UAE  
+971 4359 1988  
Erlanger, USA  
+1 859 578 2395  
Houston, USA  
+1 281 547 7422

Stockstadt, Germany  
+49 6027 4051221  
Vadodara, India  
+91 265 234 1134  
Lynbrook, Victoria, Australia  
+61 3 9771 5370  
Witham, UK  
+44 1376 517901

Contact our nearest office for a distributor near you, or check [www.sofisglobal.com/contact](http://www.sofisglobal.com/contact).