

ULTRASONIC FLOWMETER FOR STEAM

(Clamp-on Type)

DATASHEET

FSJ, FSX, FLY

This is a clamp-on type (externally-mounted type) ultrasonic flowmeter capable of measuring steam flow rate without the need for pipe cutting work.

It was previously difficult to measure the steam flow rate used in factories or plants in a various of industry sectors, but by installing this flowmeter, flow rate can now be measured even while equipment is running.

We developed an ultrasonic sensor for measuring steam with high sensitivity and new noise reduction technology, and incorporated these technologies into this ultrasonic flowmeter for measuring steam flow rate from low pressure (from 0.1 MPa (G) * Note 1) to high temperature (up to 180°C) with high precision.

Note 1) The (G) in MPa (G) indicates gauge pressure (with atmospheric pressure of 0 as baseline).



Flow transmitter
(FSJ)

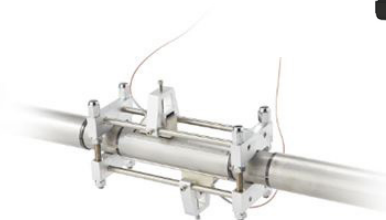

Detector (FSX)

FEATURES

1. High accuracy

Steam flow rate can be measured in the 0 to 50 m/s range, and high-precision measurement at $\pm 3.0\%$ of rate (10 to 30 m/s) is possible.

2. Measurement possible from low pressure (low temperature)

Steam flow rate can be measured from a low pressure of 0.1 MPa (G) (temperature: 120°C).

3. Zero pressure loss

No pressure loss, due to mounting externally on pipes.

4. High-speed calculation

The flowmeter is equipped with a high-performance CPU, offering high-speed response of 0.2 seconds.

5. Mass flow rate conversion

Mass flow output is possible by conversion with volume flow and density input. Density can be adjusted by pressure and temperature input.

6. Various communication functions

The flowmeter is equipped with communication functions such as RS-485 (Modbus specification), which is capable of carrying out self-diagnosis as an IoT terminal device, and features a remote diagnosis function.

7. Multi-lingual

The following languages are supported for display: Japanese (Katakana), English, German, French, and Spanish.

SPECIFICATIONS

1. General specifications

Measurement principle:

Ultrasonic transit-time difference method

System configuration:

Measurement with flow transmitter (type: FSJ) and detector (type: FSX)

Mass flow rate measurement with flow transmitter, detector, and pressure gauge/temperature sensor (analog input)

Measurement range (flow velocity):

0 to ± 50 m/s, 0 to ± 425.9 m³/h (Inner diameter 54.9 mm)

Note) Settable flow range:

0.3 to ± 50 m/s, ± 2.56 to ± 425.9 m³/h
(Inner diameter 54.9 mm)

Dimensions:

Refer to outline diagram

Power supply:

100 to 240 V AC (+10%/-15%), 50/60 Hz

Power consumption:

20 VA or less

Grounding:

Class D grounding with ground resistance of 100 Ω or less

Varistor:

Provided as standard for power supply

Arrestor:

Provided as standard for analog output

Signal cable:

2 m (between detector and pre-amplifier)

5 to 30 m (between pre-amplifier and flow transmitter)

Enclosure:

IP67 (with connectors fitting)

Ambient temperature:

-20 to +60°C (when in use)
 -20 to +65°C (when stored)

Note) Refer to the 9 pages for "Usage precautions".

Ambient humidity:

95% RH or less

Vibration resistance:

0.5 G, 5 to 200 Hz

Installation environment:

Non-explosion-proof area with no direct sunlight, corrosive gas, or radiant heat

Material:

Flow transmitter: Aluminum alloy
 Detector (sensor): Plastic, stainless steel
 Detector (sensor attachment frame): Aluminum alloy, stainless steel
 Noise elimination frame: Heat-resistant rubber, stainless steel
 Pre-amplifier: Aluminum alloy

Coating:

Flow transmitter: Urethane resin coating
 Pre-amplifier: Polyester powder paint

Finish color:

Flow transmitter (front cover): Silver
 Flow transmitter (case): Dark silver
 Pre-amplifier: Light gray

Weight:

Flow transmitter: 5.5 kg
 Detector (entire unit): 6.5 kg
 Dedicated cable (10 m): 2.1 kg
 Pre-amplifier: 1.5 kg

Dimensions:

Flow transmitter: W247 × H240 × D134 mm
 Detector (sensor): W70 × H39 × D28 mm
 Detector (sensor attachment frame): W330 × H267 × D127 mm
 Noise elimination frame: W250 × H73.6 × D65.5 mm
 Pre-amplifier: W134 × H101 × D63 mm

2. Measurement fluid specifications

Applicable fluid:

Saturated steam

Flow profile:

Fully-developed turbulent or laminar flow in round pipe

Temperature:

+120 to +180 °C

Pressure:

0.1 MPa (G) to 0.9 MPa (G)

Splashing, wetness fraction:

Wetness fraction: 0%, there should be no splashing

3. Performance

Accuracy:

- Display, pulse output:
 - ±3.0% of rate (flow velocity: 10 to 30 m/s)
 - ±5.0% of rate (flow velocity: 30 to 50 m/s)
 - ±0.3 m/s (flow velocity: 0 to 10 m/s)
- Analog output:
 - ±0.04 mA to above indicated accuracy (at ambient temperature of 25°C)

Response time:

0.2 s (standard)

Warm-up time:

Starting at the normal temperature, it takes about 10 minutes until the temperature of the detector stabilize after steam begins to flow (this depends on the facilities).

During warm-up, the measurement accuracy might not be satisfied or there may happen output holding.

4. Detector specifications (FSX)

Detector mounting method:

Clamp-on type (mounted externally on pipe)

Pipe size:

50 A (expanded lineup under development)

Pipe thickness:

2.8 to 3.9 mm (SUS pipe: sch10s to sch40), 3.8 mm (SGP pipe)

Pipe material:

Steel, stainless steel

Pipe lining material:

Not possible

Required length of straight pipe:

Upstream: 20 D or longer, downstream: 10 D or longer
 Please contact Fuji Electric for shorter straight pipe length is required.

Sensor heat-resistant temperature:

Max. 180°C

5. Flow transmitter specifications (FSJ)

Analog output signals:

4 to 20 mA DC (insulated), 1 point
 Allowable load resistance: 600 Ω or less

Analog input signals:

4 to 20 mA DC (insulated), 1 point
 Input signals: Saturated steam pressure or saturated steam temperature

Temperature input function:

Pt100: 1 point (for saturated steam temperature or pipe surface temperature)
 Measurement range: 100 to 180°C
 *Temperature sensor should be prepared separately.

Contact output signals:

Forward total, reverse total, alarms, working range, flow switch, or total switch can be allocated as required.

- Type: Transistor output, open collector output (insulated)
- Load rating: 30 V DC, 50 mA
- Number of output points: 2 points
- Max. output frequency: 100 pulses per second

Communication function:

- RS-485 (Modbus specification, insulated)
 - No. of connectable modules: Up to 31
 - Baud rate: 9600, 19200, 38400 bps
 - Parity: None/odd/even, selectable
 - Stop bit: 1 or 2 bits, selectable
 - Cable length: Up to 1 km
 - Data: Instantaneous flow velocity, instantaneous flow rate, total value, etc.
- Ethernet (option: under development)

Display device:

LCD with 2 lines of 16 characters and back light
 2-color LED (Normal: green, Extraordinary: red)

Indication language:

Japanese (Katakana)/English/French/German/Spanish (changeable)

Flow velocity/flow rate indication:

Numerals: 8 digits (incl. decimal point)
 Instantaneous flow velocity, flow rate (volumetric flow rate)
 Instantaneous flow velocity indication (minus indication for reverse flow)
 Unit:

<Table 1>

Flow velocity	m/s
Flow rate	L/s, L/min, L/h, L/d, kL/d, ML/d, m ³ /s, m ³ /min, m ³ /h, m ³ /d, km ³ /d, Mm ³ /d, BBL/s, BBL/min, BBL/h, BBL/d, kBBL/d, MBBL/d

Instantaneous flow rate (mass flow rate):

<Table 2>

Flow rate	g/s, g/min, g/h, g/d, kg/s, kg/min, kg/h, kg/d, t/s, t/min, t/h, t/d
-----------	--

Mass flow rate conversion:

Conversion from density and volumetric flow rate measurement value to mass flow rate

- Density fixed value input
- Saturated steam pressure AI input value
- Saturated steam temperature AI input value
- Temperature input

Total value indication:

Numerals: 9 digits

<Table 3>

Volumetric flow rate	mL, L, m ³ , km ³ , Mm ³ , mBBL, BBL, kBBL
Mass flow rate	g, kg, t

Pipe connection:

Refer to ordering code in the page 5.

6. Functionality**Self-diagnostic function:**

Receiving wave diagnosis, S/N diagnosis, device diagnosis, etc.

Damping:

0 to 100s (every 0.1s) for analog output and flow velocity/flow rate indication

Low flow rate cutoff:

0 to 5m/s in terms of flow velocity

Alarm:

Digital output available for Hardware fault or Process fault

Bi-directional flow measurement:

Bi-directional flow measurement and flow rate summation

Range switching and range setting range:

Single range, automatic 2 ranges, bi-directional range, bi-directional automatic 2 ranges

Troubleshooting function:

Dialog style troubleshooting display

Maintenance function:Analog output/analog input adjustment and verification
Digital output verification**Burnout:**

Analog output: Hold/Overscale/Underscale/Zero selectable

Flow rate total: Hold/Count selectable

Burnout timer: 10 to 900s (every 1s)

Bi-directional range:

Forward and reverse ranges configurable independently.

Hysteresis: 0 to 20% of working range

Working range applicable to digital output

Auto-2 range:

2 forward ranges configurable independently

Hysteresis: 0 to 20% of working range

Working range applicable to digital output

Flow switch:

Lower limit, upper limit configurable independently

Digital output available for status at actuated point

Total switch:

Forward total switching point configurable

Digital output available when actuated

Total preset:

Total flow returns to the user-defined preset value every time a user resets the total.

Backup of power failure:

backup by non-volatile memory

EU Directive Compliance

LVD (2014/35/EU)

EN 61010-1

EMC (2014/30/EU)

EN 61326-1 (Table 2)

EN 55011 (Group 1 Class A)

EN 61000-3-2 (Class A)

EN 61000-3-3

EN 61326-2-3

RoHS (2011/65/EU)

EN 50581

Physical specifications**Acoustic coupler:**

Acoustic coupler is a filling between detector and pipe.

Type of acoustic coupler:

<Table 4>

Type	High-temperature grease (for short-term installation) Name: KS-62M	High-temperature grease (for long-term installation) Name: Moly High Temp Grease
Fluid temperature	-30 to 250°C	-15 to +250°C
Expected lifetime	6 months	2 years

Note) Please contact us when using high-temperature grease (long-term type) outside of Japan.

Signal cable: (between detector and Pre-amplifier):

Structure: Heat-resisting high-frequency coaxial cable

Sheath: Flame-resisting PVC

Outer diameter: ø11.5 mm

Terminal treatment:

<Table 5>

Cable type	FLYE
Terminal to transmitted	dedicated
Terminal to detector side	dedicated

External terminal of flow transmitter:

plug terminal (Screw type euro terminal)

■PC loader software

Provided as standard

- PC/AT compatible computer
- Main functions: Software for displaying and making changes to parameters, for gathering measurement data Instantaneous flow rate, instantaneous flow velocity, total values, and error information, etc. can be imported.
- OS: Windows 7 (Professional)/ Windows 8.1 (Professional) /Windows 10 (Enterprise)
Editions in parentheses () indicate versions for which operation has been verified.
- Required memory: 125 MB or more
- Disk drive: Windows 7/ 8.1/ 10 compatible CD-ROM drive
- Hard disk drive capacity: Min. available capacity of 52 MB

Note: Communication converter

For the PC that supports RS-232C serial interface, RS-232C - RS-485 converter is needed for connecting the PC and main unit.

For the PC that does not support RS-232C serial interface, additionally, USB - RS232C converter is also needed.

<Recommendation>

[RS-232C - RS-485 converter]

RC-770X(manufactured by SYSMEX RA)

[USB - RS-232C converter]

USB-CVRS9 (manufactured by SANWA SUPPLY)

Conditions on straight pipe

(D : Inside diameter of pipe)

Classification	Upstream side	Downstream side
90° bend		
Tee		
Diffuser		
Reducer		
Various Valve	<p>In case that flow control valve exists on upstream side.</p>	<p>In case that flow control valve exists on downstream side.</p>
Pump		

MEASURING PRINCIPLE

With ultrasonic pulses propagated diagonally between the upstream and downstream sensors, flow rate is measured by detecting the time difference obtained by the flow of fluid.

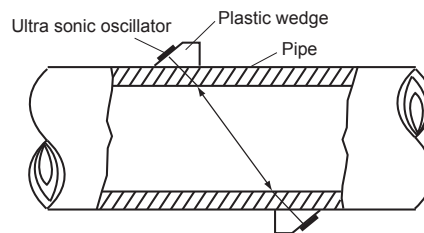
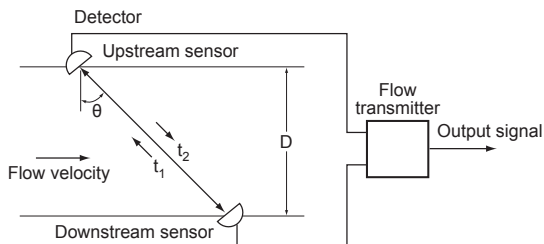

CONFIGURATION DIAGRAM

(1) Single-path system

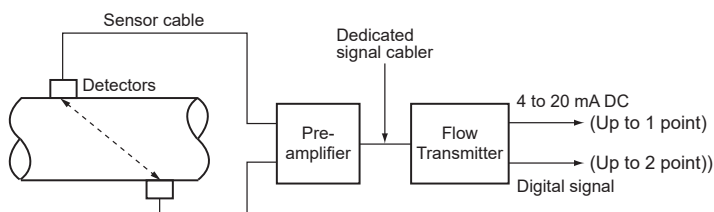

ORDERING CODE



<Flow transmitter>

Digit	Specification	Note:	4	5	6	7	8	9
			FSJ	1	Y	1	-	F
4	<Wiring port, mounting method> With water-proof gland, wall mount With union (for plica tube) gland, wall mount With water-proof gland, pipe mount With union (for plica tube) gland, pipe mount	Note: L M N P						
5	<Power Supply> 100 to 240 V AC, 50/60 Hz	1						
6	<Explosion-proof specification> None	Y						
7	<Parameter setting/tag plate (flow transmitter)> None With setting With setting + tag plate (flow transmitter) Tag plate (flow transmitter)	Y A B C						
8	Revision code	1						
9	<Option functions> Communication (RS-485)	F						

Note) Specifications for the wiring port are as follows.
With water-proof gland: G1/2 and G3/8 (female screw)
With union (for plica tube) gland: G1/2 (female screw)

<Detector>

Digit	Specification	Note:	4	5	6	7	8	9	
			FSX	5	S	Y	1	-	S
4	<Pipe diameter> 50A	5							
5	<Sensor fixing bracket, noise elimination frame> Standard	S							
6	<Explosion-proof specification> None	Y							
7	<Acoustic coupler, tag plate (detector)> None High-temperature grease (for short-term installation) High-temperature grease (for long-term installation) Tag plate (detector) High-temperature grease (for short-term installation) + tag plate (detector) High-temperature grease (for long-term installation) + tag plate (detector) Note) Please contact us if you use E and H overseas.	* Y D E F G H							
8	Revision code	1							
9	<Pre-amplifier> Standard	S							

* Note Please contact Fuji when using high-temperature grease (long-term type) outside of Japan.

<Dedicated signal cable>

Digit	Specification	Note:	4	5	6	7	8
			FLY	E			1
4	<Applications> Flow transmitter for steam (FSJ), detector for steam (FSX)	E					
5	<Dedicated cable length>						
6	5m	0 0 5					
7	10m	0 1 0					
	15m	0 1 5					
	20m	0 2 0					
	25m	0 2 5					
	30m	0 3 0					
	Other standard length (Max. 30 m)	Z Z Z					
8	Revision code	1					

OUTLINE DIAGRAM (Unit:mm)

Flow transmitter
(Type: FSJ $\begin{matrix} L \\ N \end{matrix}$)

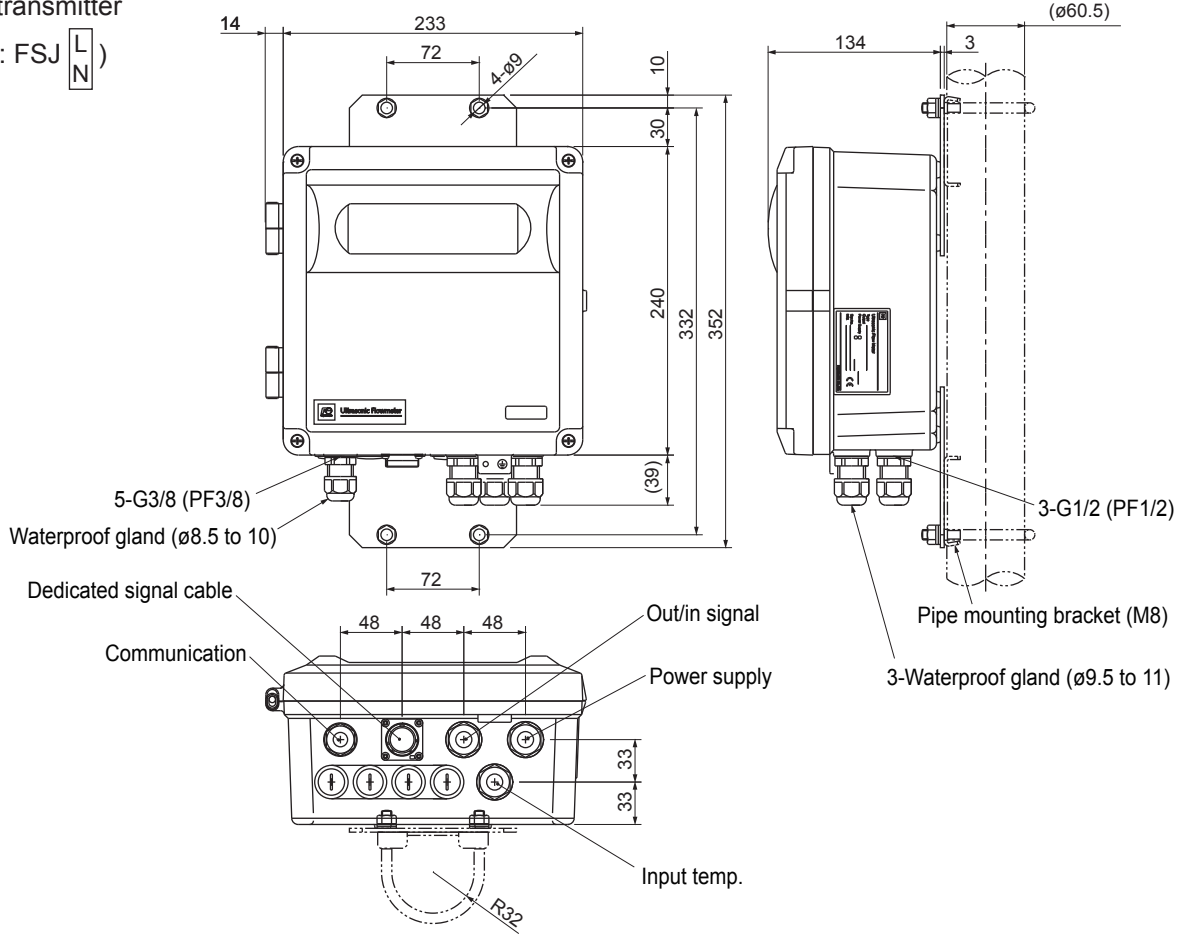

Flow transmitter
(Type: FSJ $\begin{matrix} M \\ P \end{matrix}$)

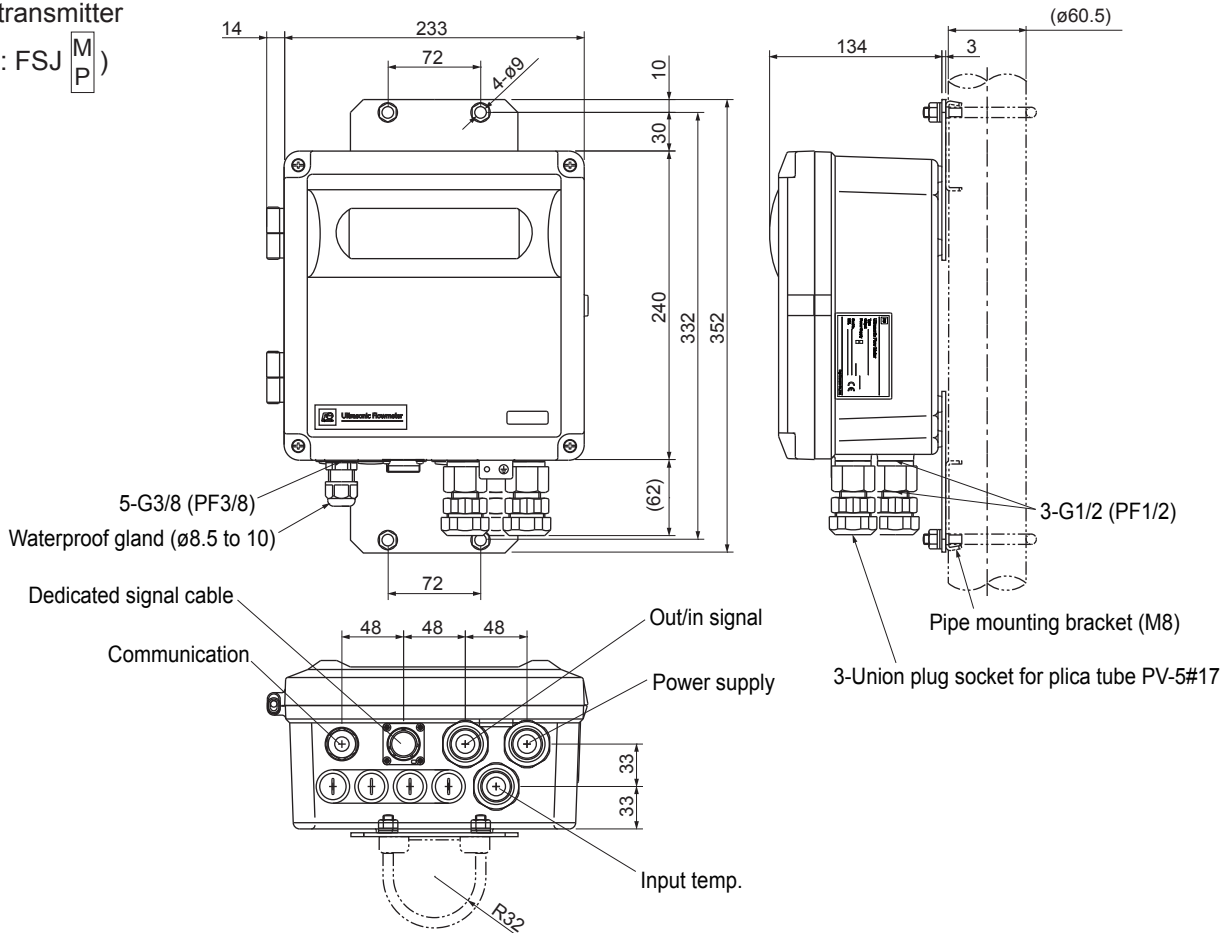

CONNECTION DIAGRAM

Flow transmitter

Terminal outline

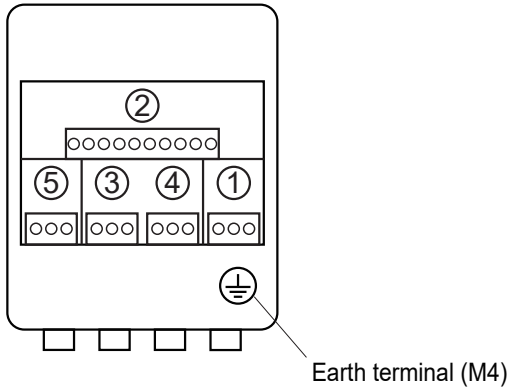

② OUTPUT/INPUT

11	12	13	14	15	16	17	18	19	20
DO1+	DO1-	DO2+	DO2-	AI+	AI-	NC	NC	AO+	AO-
DC30V, 50mA max. OUTPUT				DC4-20mA INPUT		DC4-20mA OUTPUT			

⑤ RS-485

41	42	43
SG	A-	B+
SHILD	-	+

③ TEMP. SENSOR

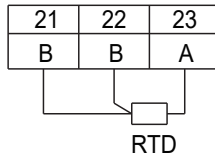

④

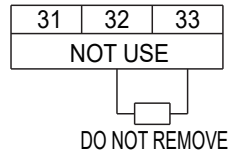

① POWER SUPPLY

1	2	3
L	N	NC

20VA 100-240VAC ~
50/60Hz



* ALLOWABLE TEMPERATURE OF
CABLE : 70°C or more

Usable wiring material

- Wire
Gauge: AWG20 (0.5mm²) to AWG16 (1.5mm²)
Strip-off length: 10mm

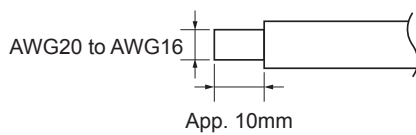

- Bar terminal
Weidmüller
www.weidmuller.com

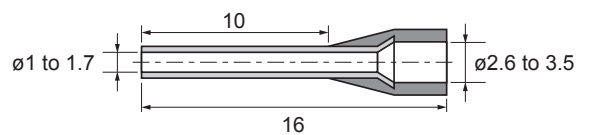

OUTLINE DIAGRAM (Unit:mm)

Detector (Type:FSX)

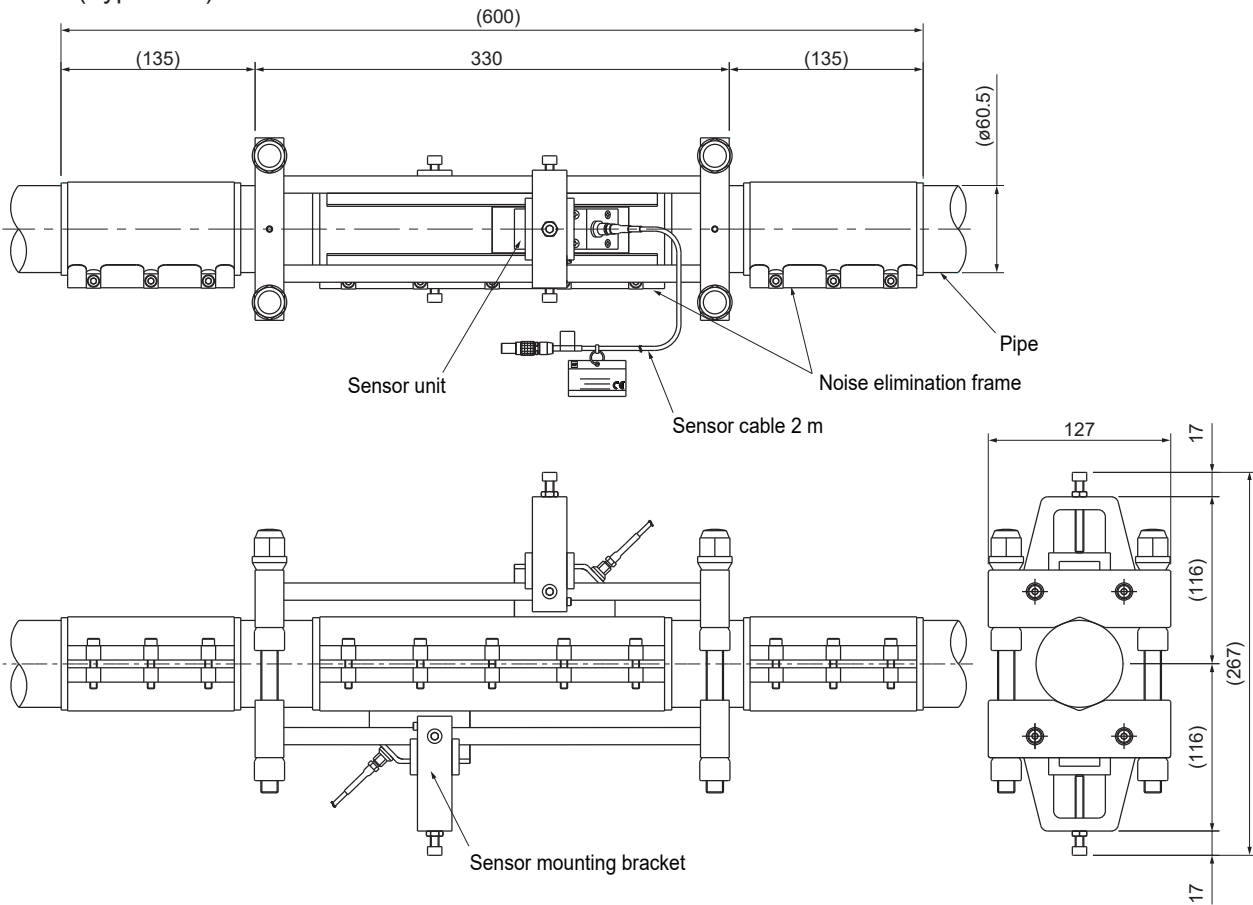

Pre-amplifier

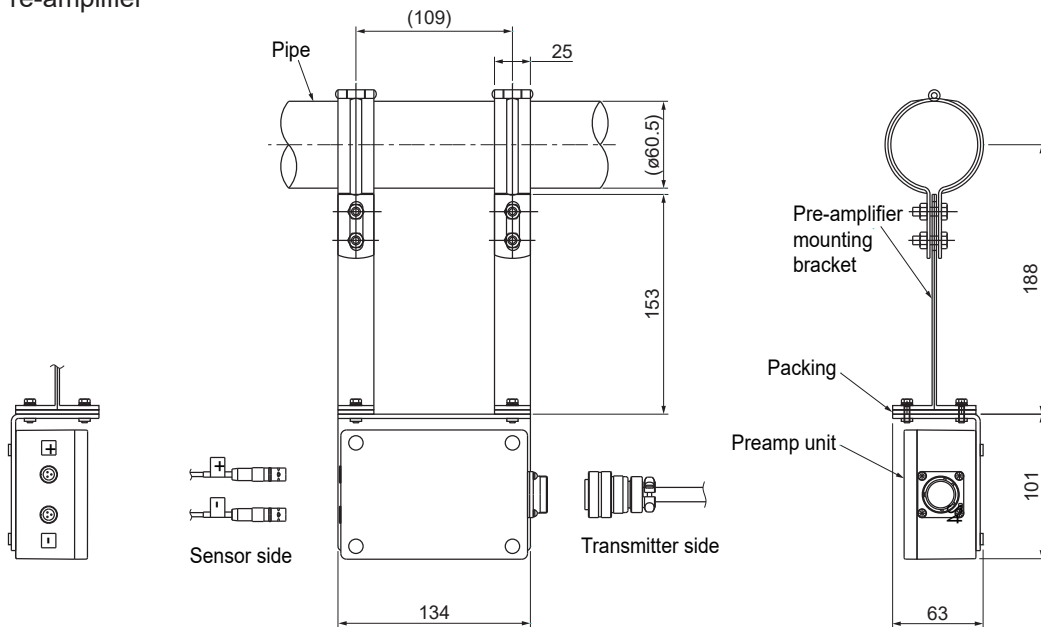

Dedicated signal cable (Type:FLYE)

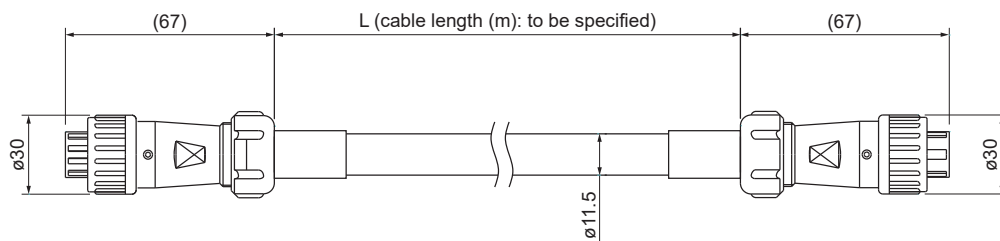

SCOPE OF DELIVERY

■ Flow transmitter: FSJ

- Flow transmitter unit
- CD-ROM (loader software for PC, instruction manual)
- Safety precautions
- Pipe mounting bracket (option) U-bolts, bracket, etc. (2 sets)

■ Detector: FSX

- Sensor unit (with sensor cable) (2 units)
- Pre-amplifier
- Pre-amplifier mounting bracket (2 sets)
- Sensor mounting bracket
- Noise elimination frame (3 frames)
- High-temperature grease (option)

■ Dedicated cable: FLYE

- Dedicated cable (length specified by user)

ITEMS DESIGNATED ORDERING

1. Detector code symbols
2. Flow transmitter code symbols
3. Signal cable code symbols
4. Tag No. as necessary (up to 8 alphanumeric characters)
5. If parameter setting is specified, send back the attached parameter specification table duly filled.

OPTIONAL ACCESSORIES

	Name	Drawing No.
1	High-temperature grease, KS-62M (for short-term installation)	ZZP* <i>TQ506697C1</i>
2	High-temperature grease, Moly High Temp Grease (for long-term installation)	ZZP* <i>TQ507247C1</i>

Items to be checked before purchase

Following conditions may cause failure of the measurement or to reduce the accuracy by this flow meter.

Please consult and ask Fuji Electric for checking with actual equipment before purchase if it is hard to judge the application is appropriate.

1) Steam

- Steam with a lot of splashing
- Overheated steam
- Steam that doesn't have wetness of 0%

2) Pipe

- Carbon steel pipe that is rough with rust on inside
- Pipe with accretions and/or sediments on inside
- Carbon steel pipe with rough outer surface
- Carbon steel pipe with uneven surface coated with rust preventive
- Steel pipe with thickness that may be out of range
- SGPW pipe [zinc-plated steel pipe for water supply (commonly known as white pipe)]

3) Length of the straight pipe

For accurate measurement, straight pipes are needed between up and down stream side of the measuring part. Please meet the straight pipe conditions according Page4.

Usage precautions

- 1) Take care not to damage the detector or signal cable installed on pipes.
- 2) It is recommended that the detector be mounted horizontally when using horizontal pipes.
- 3) When installing the detector outdoors, it is recommended that a cover be installed to prevent high-temperature grease being directly exposed to water.
- 4) After mounting the detector, always apply heat lagging materials to keep the detector and piping warm.
- 5) Do not cover the pre-amplifier with pipe thermal insulating material. Failure to observe this could result in a fault due to high-temperature.
- 6) Perform the work while making sure that water does not splash on the acoustic coupler.
- 7) When using high-temperature grease (long-term type), reapply the grease if the pipe temperature drops below -15°C when the equipment is shut off for a long time.

<Parameter specification table Measurement mode> 1/2

	Setting item	Initial value	Setting value	Setting range
1	ID №	0000		
2	LANGUAGE	English		English, Japanese, German, French, Spanish
3	SYSTEM UNIT	Metric		Metric or Inch
4	VOLUME FLOW UNIT	m ³ /h		L/s, L/min, L/h, L/d, kL/d, ML/d, m ³ /s, m ³ /min, m ³ /h, m ³ /d, km ³ /d, Mm ³ /d, BBL/s, BBL/min, BBL/h, BBL/d, kBBL/d, MBBL/d
5	VOL.TOTAL UNIT	m ³		mL, L, m ³ , km ³ , Mm ³ , mBBL, BBL, kBBL
6	MASS FLOW UNIT	kg/h		g/s, g/min, g/h, g/d, kg/s, kg/min, kg/h, kg/d, t/s, t/min, t/h, t/d
7	MASS TOTAL UNIT	kg		g, kg, t
8	PRESSURE UNIT	MPa		MPa, bar
9	TEMPERATURE UNIT	°C		°C, K, °F
10	OUTER DIAMETER	60.50 mm		[mm]
11	PIPE MATERIAL	Carbon steel		Carbon steel, Stainless
12	WALL THICKNESS	3.80 mm		[mm]
13	DENSITY	Fixed value 2.667378 kg/m ³		AI Current, Pt TEMPERATURE, Fixed value (DENSITY): [kg/m ³]
14	DAMPING	5.0 sec		[sec]
15	LOW FLOW CUT	2.40 m ³ /h		[4.UNIT]
16	1ST.ROW	VELOCITY (m/s)		VELOCITY, VOLUME FLOW RATE, VOLUME FLOW (%), MASS FLOW RATE, MASS FLOW (%), +TOTAL (VOLUME), +TOTAL PULSE (V), -TOTAL (VOLUME), -TOTAL PULSE (V), +TOTAL (MASS), +TOTAL PULSE (M), -TOTAL (MASS), -TOTAL PULSE (M), PRESSURE, TEMPERATURE, Pt TEMPERATURE, SNR, AGC
17	DECIMAL POINT POSITION	****.***		<input type="checkbox"/> <input type="checkbox"/> <input type="checkbox"/> <input type="checkbox"/> <input type="checkbox"/> <input type="checkbox"/> (Specified digit check)
18	2ND.ROW	FLOW RATE (m ³ /h)		VELOCITY, VOLUME FLOW RATE, VOLUME FLOW (%), MASS FLOW RATE, MASS FLOW (%), +TOTAL (VOLUME), +TOTAL PULSE (V), -TOTAL (VOLUME), -TOTAL PULSE (V), +TOTAL (MASS), +TOTAL PULSE (M), -TOTAL (MASS), -TOTAL PULSE (M), PRESSURE, TEMPERATURE, Pt TEMPERATURE, SNR, AGC
19	DECIMAL POINT POSITION	****.***		<input type="checkbox"/> <input type="checkbox"/> <input type="checkbox"/> <input type="checkbox"/> <input type="checkbox"/> <input type="checkbox"/> (Specified digit check)
20	AO OUT.SOURCE	VOLUME FLOW RATE		VOLUME FLOW RATE, MASS FLOW RATE
21	RANGE TYPE	Single		Single, Auto 2, Bi-dir, Bi-dir Auto 2
22	KIND	Flow rate		Velocity, Flow rate
23	VOLUME FLOW FS1	80.000 m ³ /h		[4.UNIT]
24	VOLUME FLOW FS2	0.000 m ³ /h		[4.UNIT]
25	MASS FLOW FS1	0.000 kg/h		[6.UNIT]
26	MASS FLOW FS2	0.000 kg/h		[6.UNIT]
27	HYSTERESIS	10.00%		%
28	BURNOUT (CURRENT)	Hold		Not used, Hold, Lower, Upper and Zero
29	BURNOUT TIMER	10 sec		[sec]
30	OUTPUT LIMIT LOW	-20%		[%]
31	OUTPUT LIMIT HIGH	120%		[%]
32	RATE LIMIT	40.000 m ³ /h		[4.UNIT]
33	RATE LIMIT TIMER	10 sec		[sec]
34	TOTAL MODE	STOP		START, STOP, TOTAL RESET
35	VolumeTOTAL RATE *Note1	0 m ³		[5.UNIT]
36	V:TOTAL PRESET	0 m ³		[5.UNIT]
37	MASS TOTAL RATE *Note1	0 m ³		[7.UNIT]
38	M:TOTAL PRESET	0 kg		[7.UNIT]
39	PULSE WIDTH *NOTE1	50.0 msec		5.0 msec, 10.0 msec, 50.0 msec, 100.0 msec, 200.0 msec, 500.0 msec, 1000.0 msec

Parameter specification table Measurement mode> 2/2

	Setting item	Initial value	Setting value	Setting range
40	BURNOUT (TOTAL)	Hold		Not used, Hold
41	BURNOUT TIMER	10 sec		[sec]
42	DO1 OUTPUT TYPE	Not used		<input type="checkbox"/> NOT USE <input type="checkbox"/> +Vol.TOTAL PULSE <input type="checkbox"/> -Vol.TOTAL PULSE <input type="checkbox"/> +MassTOTAL PULSE <input type="checkbox"/> -MassTOTAL PULSE <input type="checkbox"/> FULL SCALE 2 <input type="checkbox"/> ALARM [ALL, HARDWARE FAULT, PROCESS ERROR] <input type="checkbox"/> Vol.FLOW SWITCH <input type="checkbox"/> Vol.FLOW SW HIGH [[4.UNIT]] <input type="checkbox"/> Vol.FLOW SW LOW [[4.UNIT]] <input type="checkbox"/> MassFLOW SWITCH <input type="checkbox"/> MassFLOW SW HIGH [[6.UNIT]] <input type="checkbox"/> MassFLOW SW LOW [[6.UNIT]] <input type="checkbox"/> Vol.TOTAL SWITCH <input type="checkbox"/> [[5.UNIT]] <input type="checkbox"/> MassTOTAL SWITCH <input type="checkbox"/> [[7.UNIT]] <input type="checkbox"/> AO RANGE OVER <input type="checkbox"/> PULSE RANGE OVER <input type="checkbox"/> -FLOW DIRECTION <input type="checkbox"/> INPUT ALARM <input type="checkbox"/> MAINTENANCE
43	DO1 OUTPUT OPERATION	Active ON		Active ON, Active OFF
44	DO2 OUTPUT TYPE	Not used		<input type="checkbox"/> NOT USE <input type="checkbox"/> +Vol.TOTAL PULSE <input type="checkbox"/> -Vol.TOTAL PULSE <input type="checkbox"/> +MassTOTAL PULSE <input type="checkbox"/> -MassTOTAL PULSE <input type="checkbox"/> FULL SCALE 2 <input type="checkbox"/> ALARM [ALL, HARDWARE FAULT, PROCESS ERROR] <input type="checkbox"/> Vol.FLOW SWITCH <input type="checkbox"/> Vol.FLOW SW HIGH [[4.UNIT]] <input type="checkbox"/> Vol.FLOW SW LOW [[4.UNIT]] <input type="checkbox"/> MassFLOW SWITCH <input type="checkbox"/> MassFLOW SW HIGH [[6.UNIT]] <input type="checkbox"/> MassFLOW SW LOW [[6.UNIT]] <input type="checkbox"/> Vol.TOTAL SWITCH <input type="checkbox"/> [[5.UNIT]] <input type="checkbox"/> MassTOTAL SWITCH <input type="checkbox"/> [[7.UNIT]] <input type="checkbox"/> AO RANGE OVER <input type="checkbox"/> PULSE RANGE OVER <input type="checkbox"/> -FLOW DIRECTION <input type="checkbox"/> INPUT ALARM <input type="checkbox"/> MAINTENANCE
45	DO2 OUTPUT OPERATION	Active ON		Active ON, Active OFF
46	AI RANGE KIND	NOT USED		NOT USED, PRESSURE, TEMPERATURE
47	AI BASE SCALE	0		[8. or 9.UNIT]
48	AI FULL SCALE	0		[8. or 9.UNIT]
49	COMMUNICATION BAUD RATE	38400 bps		9600 bps, 19200 bps, 38400 bps
50	COMMUNICATION PARITY	Odd		None, Odd, Even
51	COMMUNICATION STOP BIT	1 bit		1 bit, 2 bits
52	COMMUNICATION STATION NO.	1		
53	LIGHTS-OUT TIME	0		[min]

Note1: When total pulse output has been selected for DO1, DO2 specify total pulse value and total pulse width so that conditions 1 and 2 shown below are satisfied.

$$\text{conditions 1: } \frac{\text{Flow span-1* [m}^3\text{/s]}}{\text{total pulse value* [m}^3\text{]}} \leq 100 \text{ [Hz]}$$

$$\text{conditions 2: } \frac{\text{Flow span-1* [m}^3\text{/s]}}{\text{total pulse value* [m}^3\text{]}} \leq \frac{1000}{2 \times \text{total pulse width [ms]}}$$

* In the case of 2 ranges, perform calculations using either flow span-1 or flow span-2, whichever is greater.



Fuji Electric France S.A.S.

46, rue Georges Besse - ZI du Brézet - 63039 Clermont-Ferrand Cedex 2 - France
 Tél. France 04 73 98 26 98 - Fax. 04 73 98 26 99 - Tel. international +33 4 73 98 26 98 - Fax. +33 4 73 98 26 99
 Email : sales.dpt@fujielectric.fr - Web : www.fujielectric.fr

Fuji Electric cannot be held responsible for any errors in our catalogues, brochures or other printed media. Fuji Electric reserves the right to modify its products without notice. This also applies to the products ordered, if the modifications do not alter the specifications substantially. The registered marks and names which appear in this document are the property of their respective depositors. All rights reserved.