

XL7-100

hygienic process viscometer

innovators in fluid measurement

Hydramotion

- ▶ increase quality, eliminate waste
- ▶ simple tank or pipeline installation
- ▶ hygienic design — no moving parts, seals or bearings
- ▶ high accuracy and repeatability

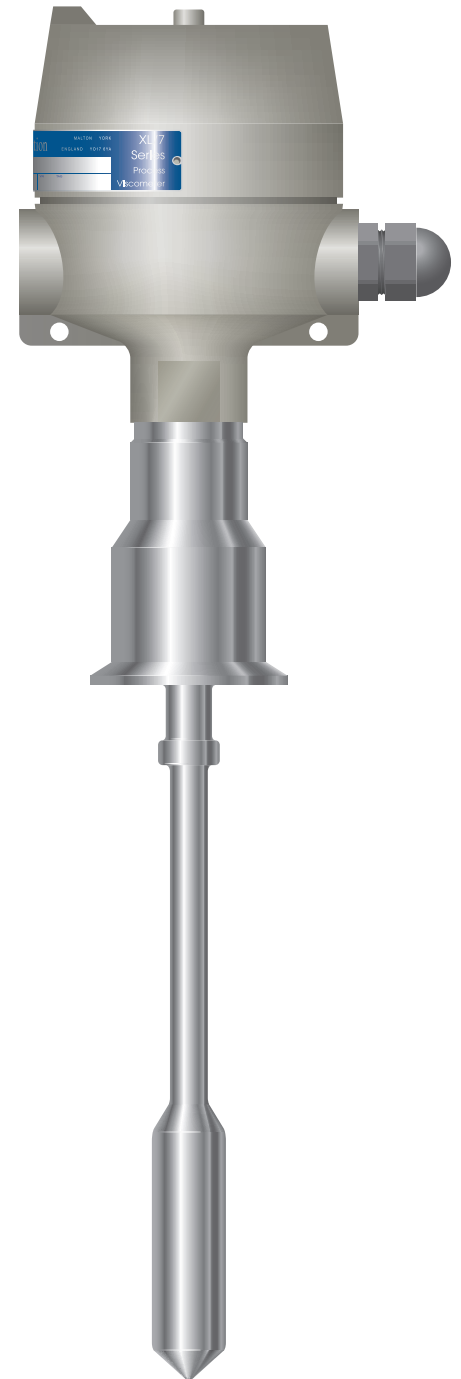
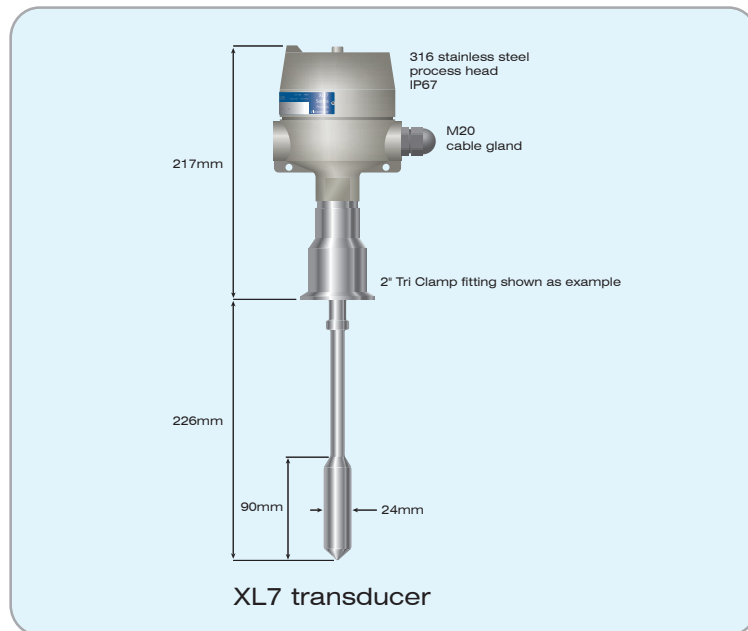

SPECIFICATION

Viscosity range	From 0 - 1 cP to 0 - 10 ⁹ cP over 10 models
Measurement time	1 second
Accuracy	1% of reading or ±1 digit
Repeatability	0.3% of reading or ±1 digit
Temperature range	-50 - +150 °C
Pressure rating	to process fitting
Process fitting	to suit application *
Cable length	as required
Cable type	standard instrument cable
Power supply	powered by signal processor
Safety certification	Safe Area
Construction	all-welded, crevice-free
Materials	head: SS316 (EN 1.4401) fitting: as required sensor: SS316/316L (EN 1.4401/1.4404) * or SAF2507 duplex steel (EN 1.4410) (optional: alloy C22, alloy C276)
Surface finish	N6 0.8 μm Ra
Ingress protection	IP67
Software	ViscoLink data viewing and logging package (Windows-based for PC)

* Custom variations to specification available to order

Hydramotion Ltd
1 York Road Park,
Malton, York,
England YO17 6VA

tel: +44 (0) 1653 600294
fax: +44 (0) 1653 693446
mail@hydramotion.com
www.hydramotion.com