

X11SN

W I N D O W A N N U N C I A T O R S Y S T E M S

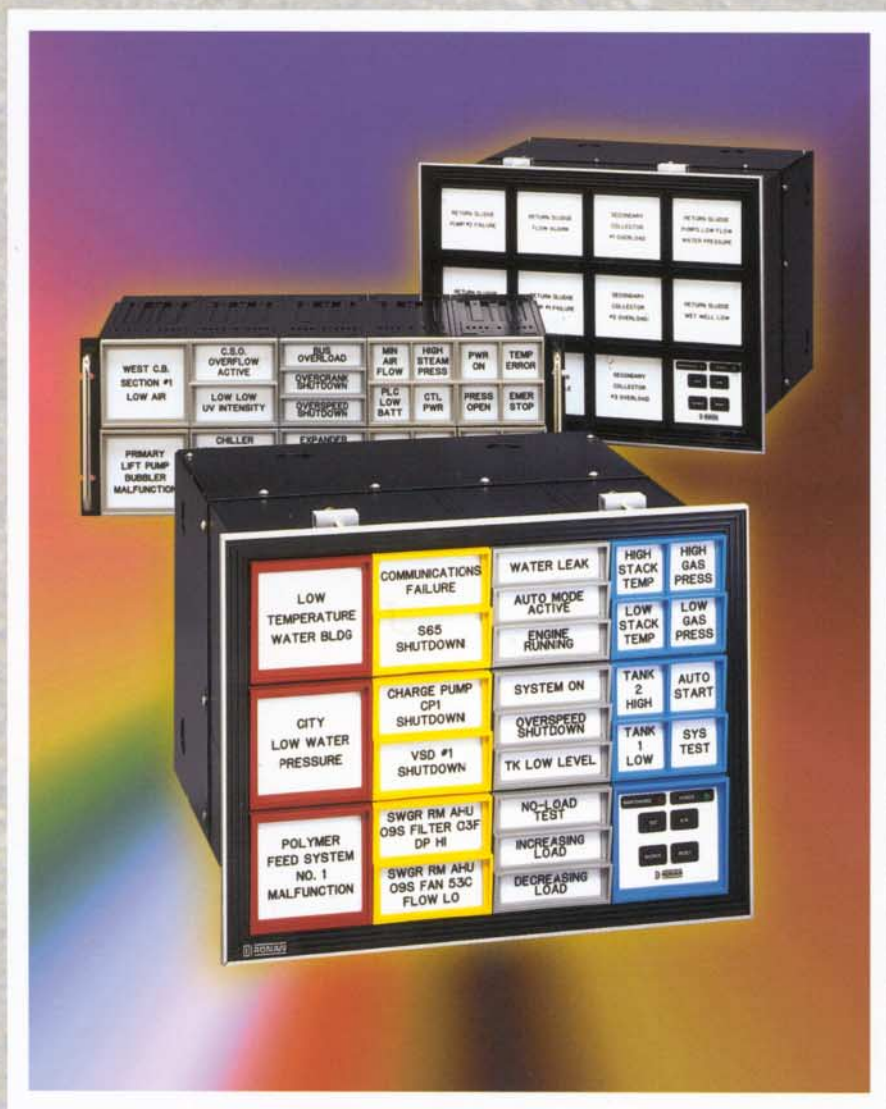

C O N T E N T S



1	SYSTEM FUNCTIONS
2	SYSTEM ENCLOSURES
3	SEQUENCE DIAGRAMS
4	MONALARM SERIES
5	DUALARM SERIES
6	TRIALARM SERIES
7	QUADALARM SERIES
8	ALARM MODULES
10	FLASHER, PUSH-BUTTON/FLASHER MODULES
11	NAMEPLATE ENGRAVINGS
12	SYSTEM COLOR CODING
13	ORDERING INFORMATION

The Ronan Series XI1SN Window Annunciator Systems are designed for the process and power industries' basic requirements, providing the most economical approach while maintaining Ronan's high quality and performance standards. The systems feature Monalarm, Dualarm, Trialarm and Quadalarm, within Ronan's standard 3.5 inch (89 mm) by 3.5 inch (89 mm) mechanical cabinet modules.

The single plug-in module construction contains single or multiple alarm circuits utilizing a Complex Programmable Logic Device (CPLD). Each module contains two of the industry's most widely popular alarm sequences (ISA 18.1). The CPLD allows factory or field reprogramming of the two sequences. Normally Open/Normally Closed field contact logic, dual horn and the two alarm sequences are DIP switch selectable. Other options available are selectable field contact time delay (50 milliseconds to 60 minutes), horn 1 auto silence (30 seconds to 10 minutes), LED or lamp display, and common trouble or system reflash alarm.

The system common trouble alarm and a per-point auxiliary relay output may be utilized for a field contact repeater or for remote group alarms. The per-point optional auxiliary relay module, equipped with one to four relays, provides a selectable Form A or Form B type dry contact. The system common reflash output allows remote reannunciation of any one window going into alarm.

The flasher, located in the lower right-hand module, limits the number of windows to two in a Trialarm or Quadalarm System. The optionally available push-button modules feature membrane push buttons, system self-monitoring for power-on, loss of power, and loss of flash, signaled by an LED and a relay contact closure.

INPUT

- Dry Contact System Powered 24 Vdc - Normally Open/Normally Closed
- Live Contact - 24 Vdc, 48 Vdc, 125 Vdc, or 115 Vac, 240 Vac
- Field Selectable by Plug-in Module
- Opto-Isolated Optional

SEQUENCE

- Dual Sequence - DIP Switch Selectable
- Any Two of the ISA 18.1 Sequences such as:
 - ISA-A and ISA-F3A, Options 2, 3
 - Multi-grouping of First Out within System
 - ISA-A and ISA-M, Options 2, 3

OUTPUTS

- Dual Audible - DIP Switch Selectable
- Auxiliary Contact
 - Double Throw Selectable Form A or Form B
 - Normally Energized or De-energized
 - GP or HS Relays
 - May be Added in the Field
- Common System Trouble Alarm Transistor Driver - Continuous Output with One or More Points in Alarm
- Reflash System Trouble Alarm - Pulse Output for Each New Alarm

DESIGN TECHNOLOGY - CPLD

- High Noise Immunity
- Field Proven Off-the-shelf Worldwide
- No Custom Integrated Circuit

EXPANDABILITY

- By Simple Exchange of Modules
- Up to 4 Times the Original Number of Points
- No Internal System Wiring Changes

LIGHTING

- Dual Bulbs - 2 Watts Each, (Quadalarm Single or Dual Bulbs)
- LED - Colors: Red, Green or Amber

COLOR CODING

- Eight Bezel Colors
- Colored Lenses *(Not Suitable for LED Displays)*
- Sandwich Lenses *(Not Suitable for LED Displays)*

WARRANTY

- Three (3) Years

APPROVALS

- UL - Underwriters Laboratories
- CUL - Canadian Underwriters Laboratories

SERVICES

- Field Start-up and Service
- Customer Training
- Complete System Documentation



The Ronan Annunciator Systems with integral electronics are assembled from basic 3.5 inch (89 mm) by 3.5 inch (89 mm) mechanical modules to fulfill the overall size requirements and the number and size of windows specified. This modular approach provides great flexibility in meeting the customers control panel dimensions.

The mechanical modules assembled from aluminum castings and extrusions provide excellent heat dissipation for a continuously lit annunciator system and feature the structural strength required in industrial applications. All enclosures are painted with black baked semigloss enamel with custom colors available optionally.

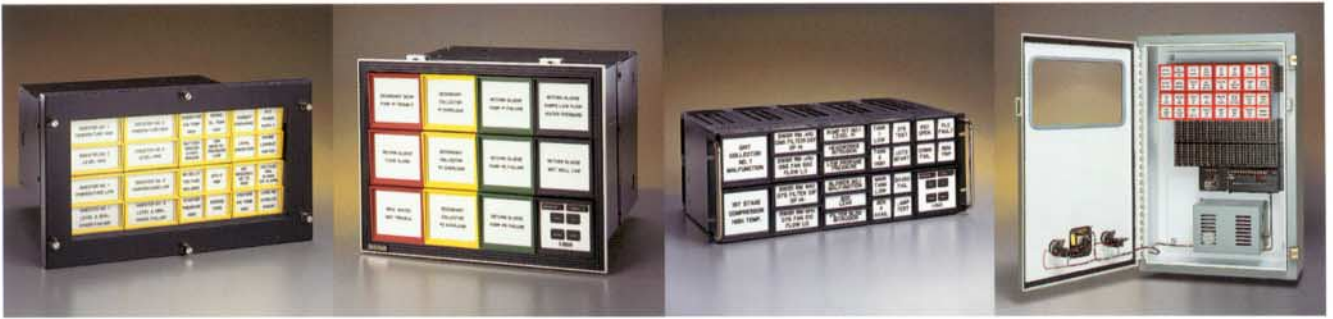

The panel mount enclosure may be enhanced with a NEMA 4 or NEMA 12 door assembly to seal the front of the alarm system against the control panel where it is subject to moisture or a corrosive atmosphere. The door is supplied with a clear acrylic window, sealed with a neoprene gasket. Gasketing is supplied for sealing between door frame and control panel.

Note: The panel cutout is the same as specified in the standard flush-mounted alarm system.

The flush-mounting NEMA 1 type enclosure, for control panel applications, feeds through a rectangular cutout and attaches to the panel with a number of simple clamping devices supplied with each system. The rear accessible terminals are enclosed with protective side and rear panels. The side panels feature pre-stamped conduit knockout entries for field wiring and power input.

The Ronan alarm systems of various window sizes are available for standard 19 inch (483 mm) or 24 inch (610 mm) relay rack mounting. The five mechanical module wide unit is suitable for 19 inch (483 mm), and the six module wide unit for 24 inch (610 mm) rack spacing.

The X11SN alarm systems are available in standardized or custom NEMA type enclosures. The NEMA 4 (IP65) or NEMA 12 enclosures may be wall mounted or floor standing and may be equipped with purging facilities to National Electrical Code types X, Y or Z.

SYSTEM EXPANDABILITY

The Series X11SN Annunciator Systems allow expandability from the originally specified window size of a Monalarm up to a Quadalarm. This up to four times expansion by simple exchange of alarm display modules and appropriate bezels is field executable at nominal cost.

When converting to the expanded system during warranty period, Ronan will make allowance on undamaged modules and bezels.

SEQUENCE A*

Automatic Reset

- Acknowledge and Test Push Buttons.
- Alarm Audible Device.
- Lock-in of Momentary Alarms until Acknowledged.
- The Audible Device is Silenced and Flashing Stops when Acknowledged.
- Automatic Reset of Acknowledged Alarm Indications when Process Conditions Return to Normal.
- Operational Test.

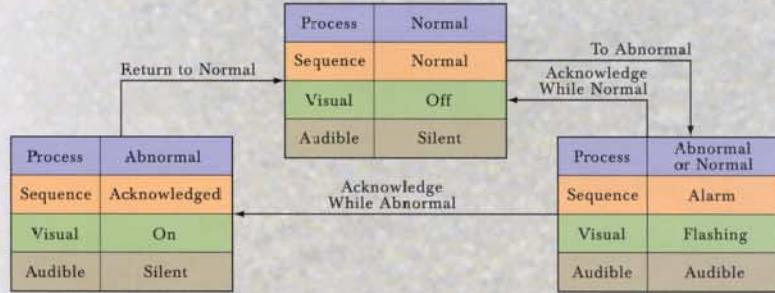

SEQUENCE F3A*

Automatic Reset

First Out with First Out Flashing and Reset Push Button

- Acknowledge, First Out Reset and Test Push Buttons.
- Alarm Audible Device.
- Lock-in of Momentary Alarms until Acknowledged.
- First Out Flashing Different from Subsequent Flashing.
- First Out Reset Push Button to Change First Out Visual Indication to be Same as Subsequent Visual Indications.
- Automatic Reset of Acknowledged Alarm Indications when Process Conditions Return to Normal.
- Operational Test.

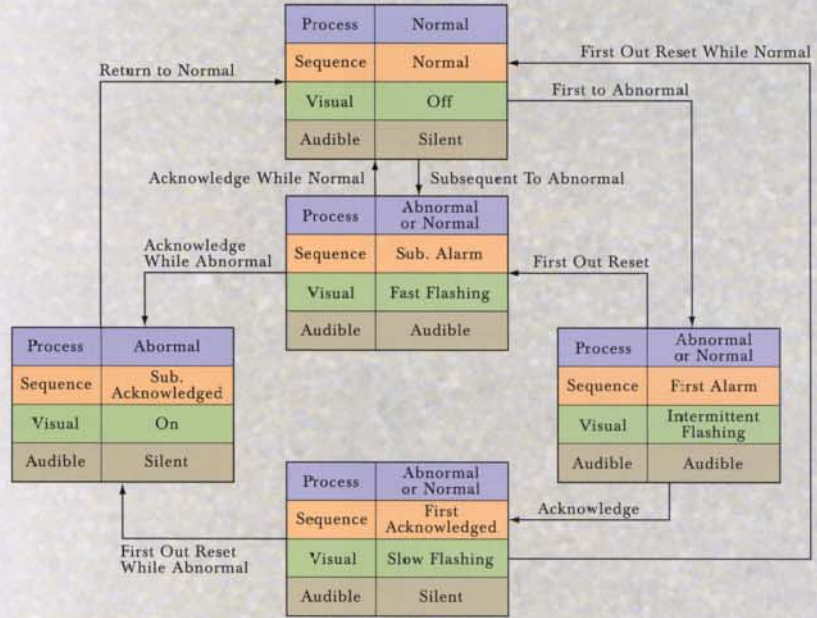

SEQUENCE M*

Manual Reset

- Acknowledge, Reset and Test Push Buttons.
- Alarm Audible Device.
- Lock-in Momentary Alarms until Acknowledged.
- The Audible Device is Silenced and Flashing Stops when Acknowledged.
- Manual Reset of Acknowledged Alarm Indications After Process Conditions Return to Normal.
- Operational Test.

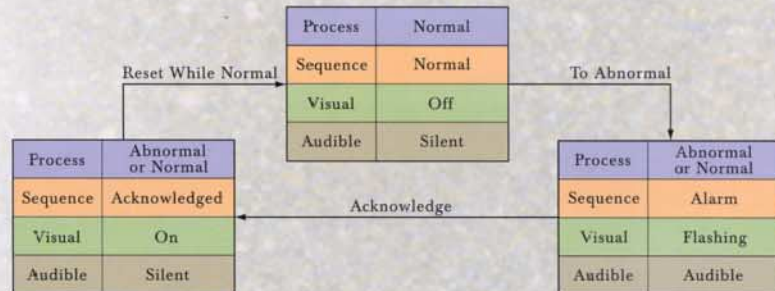

*For other sequences contact factory or see enclosures.

MODEL X11SN-1000

Flush Mounting Type for Control Panels

Nameplate Size 2.75 inches (69.85 mm) x 3.00 inches (76.20 mm).
These systems are intermixable.

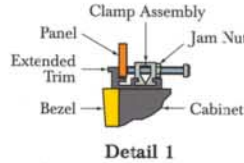
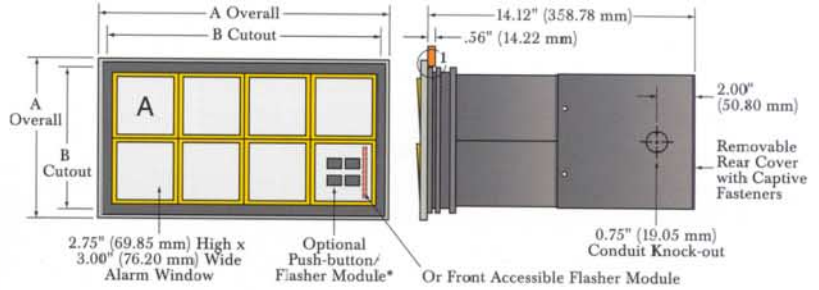

*The integral Push-button Station with on board Flasher/Horn Driver is available as an option and will occupy the position as shown. Push-button Stations will operate in conjunction with externally wired push buttons.

The lower right hand position houses the Flasher/Horn Driver Module, if Push-button/Flasher Module is not used.

Number of Windows High or Wide	A Overall		B Cutout	
	In.	mm	In.	mm
1	5.00	127.00	4.38	111.25
2	8.50	215.90	7.88	200.15
3	12.00	304.80	11.38	289.05
4	15.50	393.70	14.88	377.95
5	19.00	482.60	18.38	466.85
6	22.50	571.50	21.88	555.75
7	26.00	660.40	25.38	644.65
8	29.50	749.30	28.88	733.55
9	33.00	838.20	32.50	825.50
10	36.50	927.10	36.00	914.40
11	40.00	1016.00	39.50	1003.30
12	43.50	1104.90	43.00	1092.20

MODEL X11SNRR-1000

Relay Rack Mounting Type

19.00 inch (482.60 mm) Rack Mounting – Standard
24.00 inch (609.60 mm) Rack Mounting – Optional

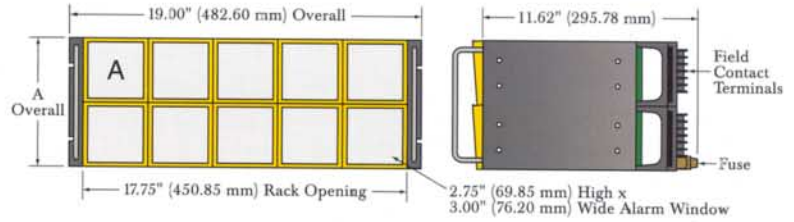

Number of Windows High	Number of Windows Wide	A Overall	
		In.	mm
1	5**	3.50	88.90
2	5	7.00	177.80
3	5	10.50	266.70
4*	5	14.00	355.60

*Not limited to 2 high.
**Limited to 5 wide only. 19.00" (482.60 mm) rack.
Also available 6 wide. 24.00" (609.60 mm) rack.

SERIES X11SN-1000

Rear Terminal Arrangement and Wiring

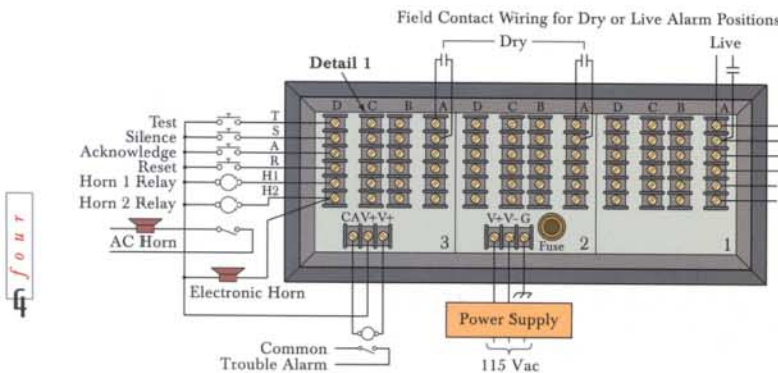

Detail 1 (Last Position Only)

- F1 Flasher Sync. for Multi-chassis Applications
- F2 +24 Vdc Input to Activate Maintenance Required Relay and LED
- F3 Reflash Output or Lamp Inhibit +24 Vdc
- F4 Maintenance Required Dry Contact
- F5
- F6

Notes:

- (ME) Connect all first out windows in a group.
- Auxiliary output N.O./N.C. selectable.
- (F1, F2) Flasher sync. connect for multi-alarm applications.
- (F3) Apply +24 Vdc to activate maintenance required LED and relay.
- (F4) Reflash output or apply +24 Vdc for lamp inhibit.
- (F5, F6) Maintenance required relay contact out.
- (CA) Common trouble alarm transistor driver.
- (H) Field contact voltage for dry contact or live input.
- (FC) Field contact return.



MODEL X11SN-2000

Flush Mounting Type for Control Panels

Nameplate Size 1.44 inches (36.58 mm) x 3.00 inches (76.20 mm).
These systems are intermixable.

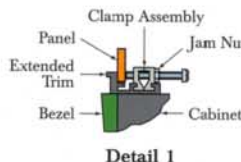
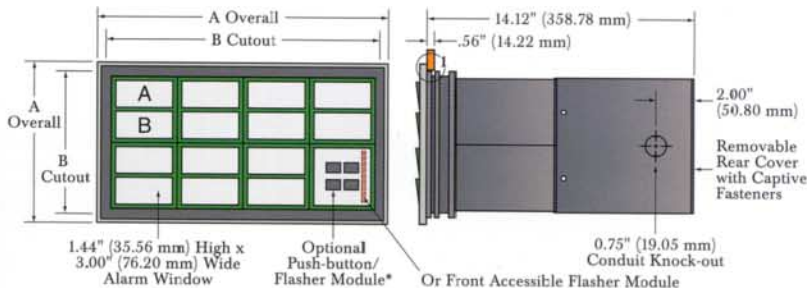

Number of Windows	High	Wide	A Overall		B Cutout	
			In.	mm	In.	mm
2	1	5.00	127.00	4.38	111.25	
4	2	8.50	215.90	7.88	200.15	
6	3	12.00	304.80	11.38	289.05	
8	4	15.50	393.70	14.88	377.95	
10	5	19.00	482.60	18.38	466.85	
12	6	22.50	571.50	21.88	555.75	
14	7	26.00	660.40	25.38	644.65	
16	8	29.50	749.30	28.88	733.55	
18	9	33.00	838.20	32.50	825.50	
20	10	36.50	927.10	36.00	914.40	
22	11	40.00	1016.00	39.50	1003.30	
24	12	43.50	1104.90	43.00	1092.20	

*The integral Push-button Station with on board Flasher/Horn Driver is available as an option and will occupy the position as shown. Push-button Stations will operate in conjunction with externally wired push buttons.
The lower right hand position houses the Flasher/Horn Driver Module, if Push-button/Flasher Module is not used.

MODEL X11SNRR-2000

Relay Rack Mounting Type

19.00 inch (482.60 mm) Rack Mounting - Standard
24.00 inch (609.60 mm) Rack Mounting - Optional

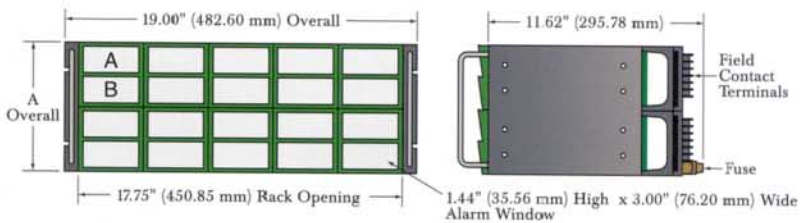

Number of Windows High	Number of Windows Wide	A Overall	
		In.	mm
2	5**	3.50	88.90
4	5	7.00	177.80
6	5	10.50	266.70
8*	5	14.00	355.60

*Not limited to 4 high.
**Limited to 5 wide only. 19.00" (482.50 mm) rack.
Also available 6 wide. 24.00" (609.60 mm) rack.

SERIES X11SN-2000

Rear Terminal Arrangement and Wiring

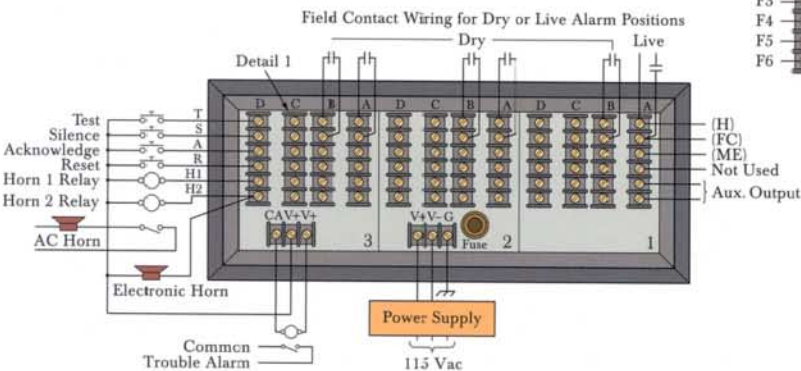

Detail 1 (Last Position Only)

- F1 Flasher Sync. for Multi-chassis Applications
- F2 +24 Vdc Input to Activate Maintenance Required Relay and LED
- F3 Refresh Output or Lamp Inhibit +24 Vdc
- F4 Maintenance Required Dry Contact
- F5
- F6

- Notes:
- (ME) Connect all first out windows in a group.
 - Auxiliary output N.O./N.C. selectable.
 - (F1, F2) Flasher sync. connect for multi-alarm applications.
 - (F3) Apply +24 Vdc to activate maintenance required LED and relay.
 - (F4) Refresh output or apply +24 Vdc for lamp inhibit.
 - (F5, F6) Maintenance required relay contact out.
 - (CA) Common trouble alarm transistor driver.
 - (H) Field contact voltage for dry contact or live input.
 - (FC) Field contact return.



Fire

TRIALARM Series

MODEL X11SN-3000

Flush Mounting Type for Control Panels

Nameplate Size .86 inches (21.84 mm) x 3.00 inches (76.20 mm). These systems are intermixable.

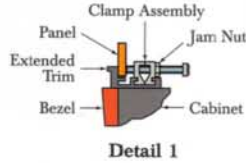
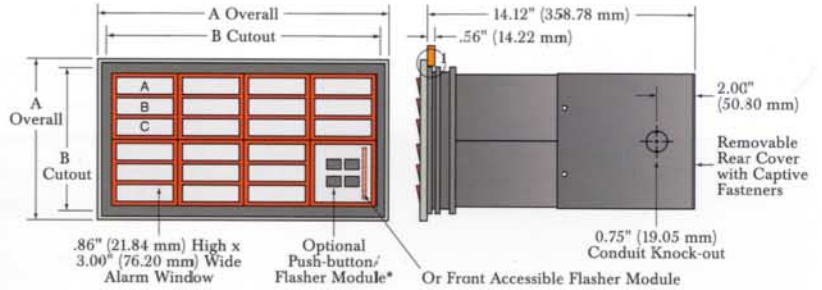

*The integral Push-button Station with on board Flasher/Horn Driver is available as an option and will occupy the position as shown. Push-button Stations will operate in conjunction with externally wired push buttons.

The lower right hand position houses the Flasher/Horn Driver Module, if Push-button/Flasher Module is not used.

Number of Windows	A Overall		B Cutout		
	High	Wide	In.	mm	
3	1	5.00	127.00	4.38	111.25
6	2	8.50	215.90	7.88	200.15
9	3	12.00	304.80	11.38	289.05
12	4	15.50	393.70	14.88	377.95
15	5	19.00	482.60	18.38	466.85
18	6	22.50	571.50	21.88	555.75
21	7	26.00	660.40	25.38	644.65
24	8	29.50	749.30	28.88	733.55
27	9	33.00	838.20	32.38	822.50
30	10	36.50	927.10	36.00	914.40
33	11	40.00	1016.00	39.50	1003.30
36	12	43.50	1104.90	43.00	1092.20

MODEL X11SNRR-3000

Relay Rack Mounting Type

19.00 inch (482.60 mm) Rack Mounting – Standard
24.00 inch (609.60 mm) Rack Mounting – Optional

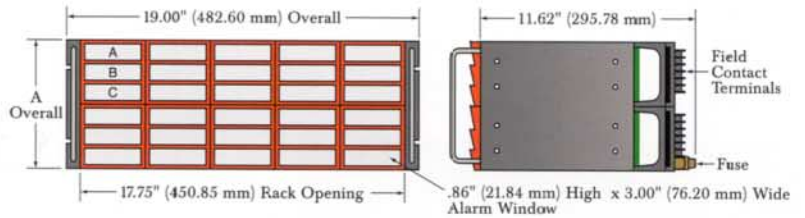

Number of Windows High	Number of Windows Wide	A Overall	
		In.	mm
3	5**	3.50	88.90
6	5	7.00	177.80
9	5	10.50	266.70
12*	5	14.00	355.60

*Not limited to 6 high.
**Limited to 5 wide only 19.00" (482.60 mm) rack.
Also available 6 wide. 24.00" (609.60 mm) rack.

SERIES X11SN-3000

Rear Terminal Arrangement and Wiring

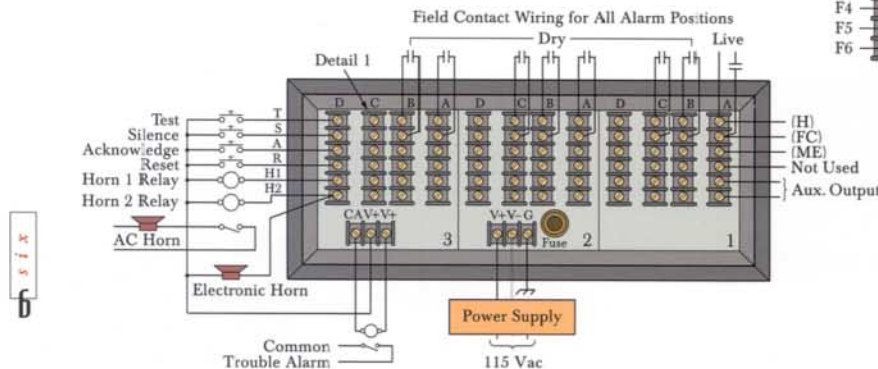

Detail 1 (Last Position Only)

- F1 } Flasher Sync. for Multi-chassis Applications
- F2 } +24 Vdc Input to Activate Maintenance Required Relay and LED
- F3 } Reflash Output or Lamp Inhibit +24 Vdc
- F4 } Maintenance Required Dry Contact
- F5 } Maintenance Required Dry Contact
- F6 } Maintenance Required Dry Contact

Notes:

- (ME) Connect all first out windows in a group.
- Auxiliary output N.O./N.C. selectable.
- (F1, F2) Flasher sync. connect for multi-alarm applications.
- (F3) Apply +24 Vdc to activate maintenance required LED and relay.
- (F4) Reflash output or apply +24 Vdc for lamp inhibit.
- (F5, F6) Maintenance required relay contact out.
- (CA) Common trouble alarm transistor driver.
- (H) Field contact voltage for dry contact or live input.
- (FC) Field contact return.
- Two windows only in lower right position (flasher location).



QUADALARM Series

MODEL X11SN-4000

Flush Mounting Type for Control Panels

Nameplate Size 1.40 inches (35.56 mm) x 1.40 inches (35.56 mm).
These systems are intermixable.

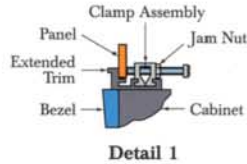
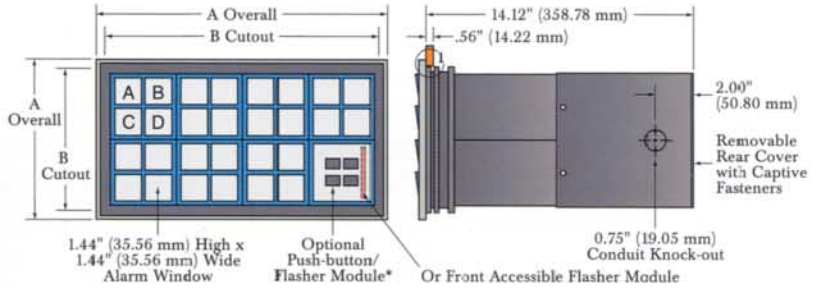

*The integral Push-button Station with on board Flasher/Horn Driver is available as an option and will occupy the position as shown. Push-button Stations will operate in conjunction with externally wired push buttons.

The lower right hand position houses the Flasher/Horn Driver Module, if Push-button/Flasher Module is not used.

Number of Windows High or Wide	A Overall		B Cutout	
	In.	mm	In.	mm
2	5.00	127.00	4.38	111.25
4	8.50	215.90	7.88	200.15
6	12.00	304.80	11.38	289.05
8	15.50	393.70	14.88	377.95
10	19.00	482.60	18.38	466.85
12	22.50	571.50	21.88	555.75
14	26.00	660.40	25.38	644.65
16	29.50	749.30	28.88	733.55
18	33.00	838.20	32.38	822.50
20	36.50	927.10	35.88	911.40
22	40.00	1016.00	39.38	1000.30
24	43.50	1104.90	42.88	1089.20

MODEL X11SNRR-4000

Relay Rack Mounting Type

19.00 inch (482.60 mm) Rack Mounting – Standard
24.00 inch (609.60 mm) Rack Mounting – Optional

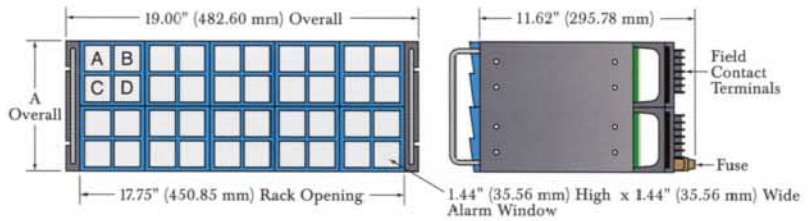

Number of Windows High	Number of Windows Wide	A Overall	
		In.	mm
2	10**	3.50	88.90
4	10	7.00	177.80
6	10	10.50	266.70
8*	10	14.00	355.60

*Not limited to 4 high.
**Limited to 5 wide only. 19.00" (482.60 mm) rack.
Also available 6 wide. 24.00" (609.60 mm) rack.

SERIES X11SN-4000

Rear Terminal Arrangement and Wiring

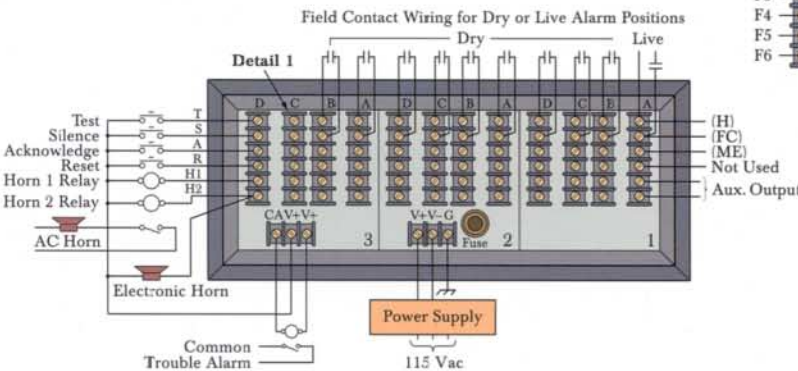

Detail 1 (Last Position Only)

- F1 Flasher Sync. for Multi-chassis Applications
- F2 +24 Vdc Input to Activate Maintenance Required Relay and LED
- F3 Reflash Output or Lamp Inhibit +24 Vdc
- F4 Maintenance Required Dry Contact
- F5
- F6

Notes:

- (ME) Connect all first out windows in a group.
- Auxiliary output N.O./N.C. selectable.
- (F1, F2) Flasher sync. connect for multi-alarm applications.
- (F3) Apply +24 Vdc to activate maintenance required LED and relay.
- (F4) Reflash output or apply +24 Vdc for lamp inhibit.
- (F5, F6) Maintenance required relay contact out.
- (CA) Common trouble alarm transistor driver.
- (H) Field contact voltage for dry contact or live input.
- (FC) Field contact return.
- Two windows only in lower right position (flasher location).



ALARM SEQUENCE/DISPLAY MODULE

The Model X11SN is offered in two dual sequence configurations selected from any of the ISA 18.1 or custom sequences. The commonly used ISA-A, and the popular first-out ISA-F3A or ISA-A and ISA-M manual resets are the most typical type of sequences selected. The selection between the two specified sequences is made for each individual window by means of slide switches. Other, by window, slide switch selections are for horn 1 or horn 2, auxiliary relay behavior, e.g. normally energized/deenergized, and special functions such as time delay for alarm acceptance. Each combination alarm/display module contains a single, dual, triple, or quad alarm channel circuit with associated dual lamps or LED display.

The modules are removable from the front of the system without interference with the remaining modules. The window display areas are contained within the Ronan standard colored bezels, and the single or sandwich lens allows multiline engraving. The alarm logic may interface with Normally Open/Normally Closed field contacts. The field contacts are interrogated by the system's power supply or external power sources. The alarm modules may be selected at purchase for dry or live field contact voltages from 24 Vdc, 48 Vdc or 125 Vdc. Optionally, a piggy-back board is provided for opto-isolation for 24 Vac, 115 Vac, 230 Vac or 125 Vdc to isolate the field contact voltage from the alarm logic/lamp voltage.

Monalarm

The Monalarm plug-in Module features single channel alarm logic with two 3-watt incandescent or optional LED type indicators illuminating a 2.75 inch (70 mm) high by 3 inch (76 mm) wide window. Each set is driven by one channel of the four-channel alarm logic.

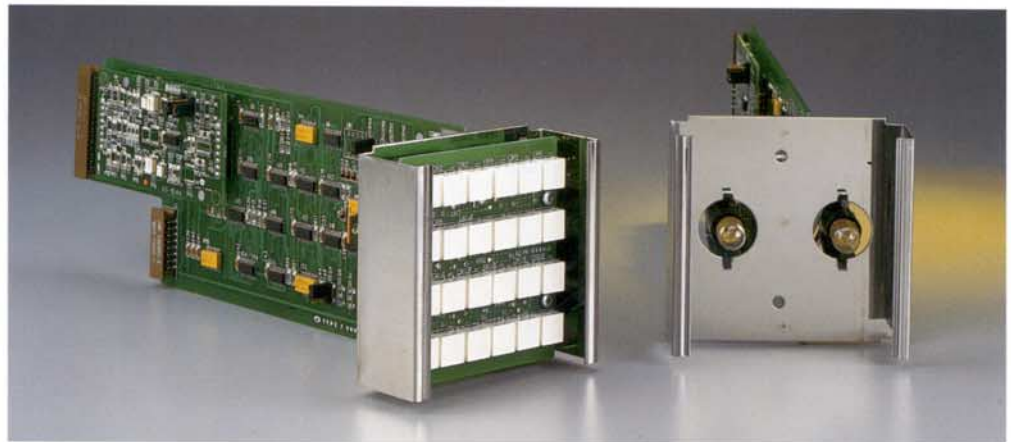
**Dualarm**

The double window Dualarm Module contains two channels of alarm logic to display alarm conditions on two windows, sized for 1.44 inch (36 mm) high and 3 inch (76 mm) wide lenses. Each window is illuminated by two 2-watt lamps or LED type indicators. Each set is driven by one channel of the four-channel alarm logic.



OUTPUT FEATURES

The Model X11SN System provides a number of special features such as common trouble alarm (CTA), dual horn output, attended/unattended lamp control, short circuit lamp drivers, and maintenance required LED indicator with relay output contact.

The CTA output provides for connection of an external relay to annunciate an alarm condition if any one or more points in the system are in alarm. A reflash output on F4 of the master terminal may be requested at the time of order.

The two horn outputs can selectively be assigned for each window to alarm, or for ringback or high/low priority.

The lamps may be inhibited without affecting the operation of the alarm logic by applying +24 Vdc to the F4 master terminal.

Maintenance required, e.g. loss of flasher or external function such as ground fault, will be indicated on the red LED located on the push-button front panel or an integral relay transfer with selectable NormallyOpen/NormallyClosed contact on F5 and F6 master terminals. A green LED on the push-button module indicates power on. The maintenance relay and red LED may be externally activated by applying 24 Vdc to the F3 master terminal.



Trialarm

The three window Trialarm Module provides three 0.86 inch (22 mm) high by 3 inch (76 mm) wide nameplates and is illuminated by three sets of two 2-watt lamps or optional LED type indicators. Each set is driven by one channel of the four-channel alarm logic.



Quadalarm

The four window Quadalarm Module represents the highest density of annunciation in the X11SN Series. The 1.44 inch (36 mm) high by 1.44 inch (36 mm) wide window is illuminated by one 2-watt lamp (optionally two 2-watt lamps) or LED type indicator. Each set is driven by one channel of the four-channel alarm logic.

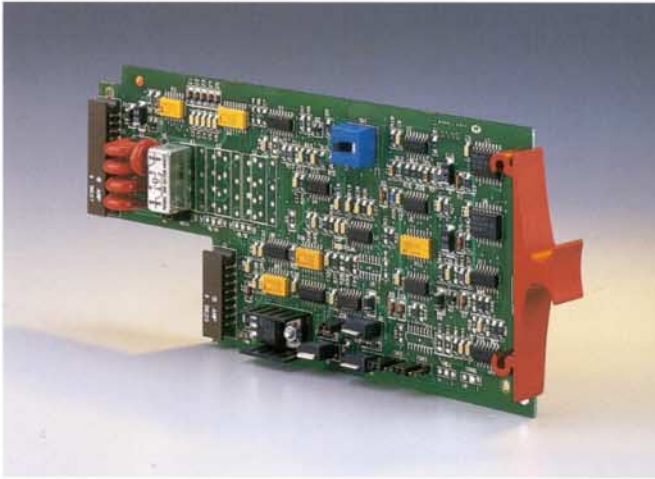

The dual frequency flash signal generator, audible driver, and push-button interface modules are located in the lower right-hand cabinet module of each system. This limits the cabinet module to two alarm windows, e.g. two windows in the quadalarm system.

The flasher module board behavior selection (see page 13) provides for different common trouble alarm (CTA) and horn performance, and availability of a reflash output on the F4 master terminal for remote annunciation of any window in the system going into alarm.

The flasher module is capable of driving up to 150 points of alarm.* Additional flashers are required for larger systems or multi-system installations. To allow synchronization of all flashers, one has to be set as

the master, and all others set into the slave position on the onboard selector slide switch.

The push-button/flasher/audible module may replace the integral flasher. This module provides additional features such as maintenance required, indicated by a red LED and relay contact output on the master terminal. The LED and relay may also be activated by the application of 24 Vdc to the F3 master terminal for additional trouble indication such as ground fault or loss of power source, etc. A green LED indicates power ON.

**For systems with more than 150 windows, a mechanical module for an additional flasher position should be located on the right side of the system (front view) after the 150th window. The maximum number of windows in this mechanical module is two.*

AUXILIARY CONTACT MODULE

The auxiliary contact module is available with single, dual, triple or quad relay circuit, according to the window density selection. The modules plug in from the front of the system with the alarm display module removed. They may be purchased initially or added later in the field without any additional system components. Each relay provides for a form A or B type contact, normally open or normally closed, and normally energized or normally not energized. Selectable by jumper switch.

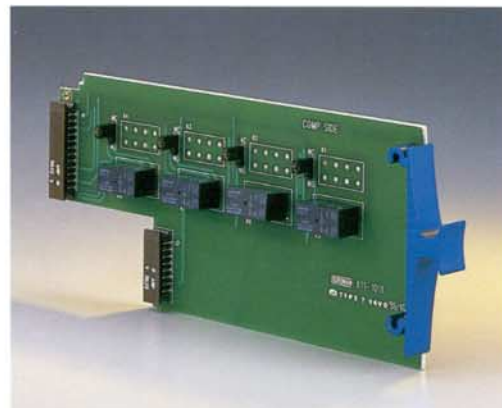

NAMEPLATE *Engravings*

Letter Size (Inches)

Characters per Line

Number of Lines

Bezels Shown Actual Size



Monalarm Series 1000 – Model WB1-()*



Dualalarm Series 2000 – Model WB2-()*



Trialarm Series 3000 – Model WB3-()*

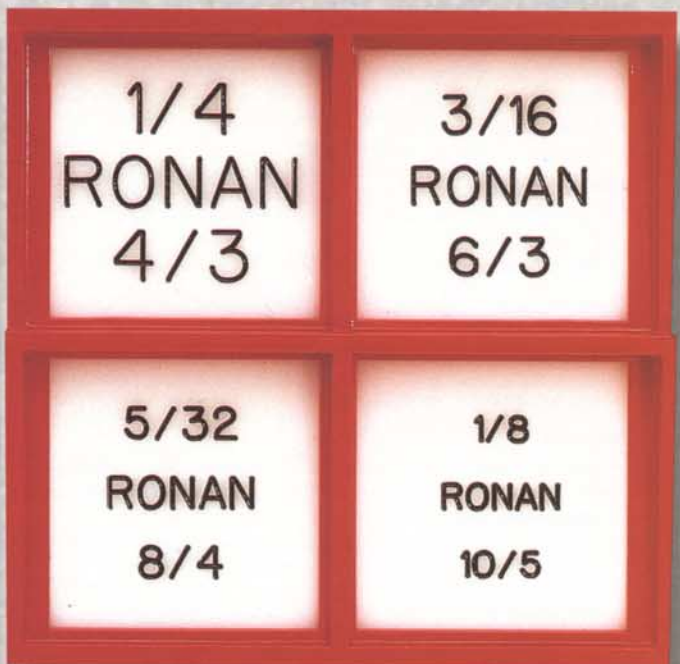

Quadalarm Series 4000 – Model WB4-()*

Bezel Colors Available



Black (0)

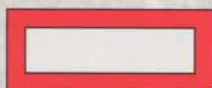

Red (2)

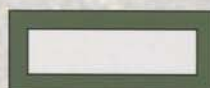

Green (5)



Grey (8)



Brown (1)



Yellow (4)



Blue (6)

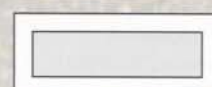

White (9)

**Color Code*

Typical bezel ordering information: WB5-(0) = Black bezel for Trialarm Series

Display and Nameplates – Ronan’s X11SN Window Annunciator may be color coded by plant or process function with colored bezels and solid color or sandwich type nameplates.

Bezels – The Bezels are available in eight (8) colors without additional cost, allowing very distinct differentiation between groups of internal system’s function, e.g., same sequence, first out groups, common alarm groups, etc., or plant and process groups of similar functions.

Colored Nameplates – The Nameplates may be supplied in five distinct standard colors to identify functions such as fire alarm, shutdown, etc.

Sandwich Nameplates – The Sandwich Nameplates, an option exclusive to the Ronan Visual Annunciator, are generally supplied with white front lenses and colored back lenses. This lens combination displays all windows white in non-lit status, changing to the selected color in OFF-Normal condition.

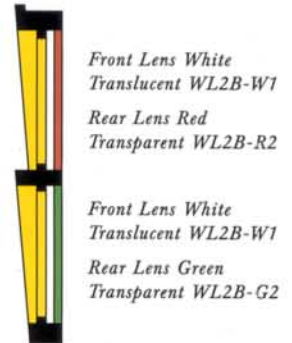

Typical Bezel WB2

GENERAL SPECIFICATIONS

System Voltage:

- Lamps, Logic – 24 Vdc ± 20%
- Field Contacts – 24 Vdc, 48 Vdc, 125 Vdc, 115 Vac, or 240 Vac

Power Source (System External):

- Power Supply – 115 Vac 50/60 Hz; 240 Vac 50/60 Hz
- Converter – 24 Vdc, 48 Vdc, or 125 Vdc

Temperature Range:

- Operating – 0° to 60° C (32° to 140° F)
- Storage – -40° to +60° C (-40° to +140° F)

Inputs:

- Contact – Dry or Live; Normally Open / Normally Closed; Field Selectable
- Interrogation Voltage – 24 Vdc, 48 Vdc, 125 Vdc, 115 Vac, or 240 Vac

Response Time: 10 milliseconds

Surge Withstand Capability (SWC):

- Input and Power Connection – IEEE 472-1974 and ANSI/IEEE C37-90-1978

Outputs:

- Visual – Fast Flash, Slow Flash, Steady ON, Intermittent Fast Flash
- Audible – Dual, Selectable by Cabinet Module
- Auxiliary Relays – Form C, Selectable Form A or B; Normally Not Energized or Normally Energized
- Contact Rating – General Purpose: 2 Amp. @ 28 Vdc; .65 Amp. @ 115 Vac
- Common System Relay – Selectable Retransmit or Common Trouble Alarm
- Contact Rating – General Purpose and Hermetically Sealed; 10 Amp. @ 28 Vdc, 10 Amp. @ 115 Vac

Controls:

- Momentary Push Button – Integral or Remote; Single Pole, Normally Open; +V Switched; Silence, Acknowledge, Reset, Test

System Size:

- Basic Cabinet Module – 3.5 inch (89 mm) x 3.5 inch (89 mm); For detailed sizes see pages 4, 5, 6 and 7

System Weight:

- Per Cabinet Module – 2.5 pounds (1.134 kg), not including Power Supply

POWER REQUIREMENTS

To specify the correct power supply, count the number of alarm modules you need to power from the supply. Calculate the total requirement as follows:

Total Watts = Number of Modules x Factor F + (F Aux.)

Model	F Lamps	F LEDs	F Aux. Relay Adder
X11SN (1000 Series)	5.3 W	7.1 W	1 W
X11SN (2000 Series)	9.3 W	7.1 W	2 W
X11SN (3000 Series)	13.3 W	5.6 W	3 W
X11SN (4000 Series)	9.3 W	7.1 W	4 W

Match the total wattage with the next higher power rating of the Power Supply or Converter listed.

DC/DC Converters

Model - Power Failure, Circuit Breaker, Power ON Light, Diode Gated

- 125 - 24/125 - 150 SCP
- 125 - 24/125 - 300 SCP
- 125 - 24/125 - 600 SCP
- 48 - 24/125 - 150 SCP
- 48 - 24/125 - 300 SCP
- 48 - 24/125 - 600 SCP

AC/DC Power Supplies

- 115 - 24 - 125
- 115 - 24 - 250
- 115 - 24 - 375
- 116 - 24 - 500
- 115 - 24 - 750
- 220 - 24 - 125
- 220 - 24 - 250
- 220 - 24 - 375
- 220 - 24 - 500
- 220 - 24 - 750
- 115 - 24/125 - 125
- 115 - 24/125 - 250
- 115 - 24/125 - 375
- 116 - 24/125 - 500
- 115 - 24/125 - 750
- 115 - 24 - 250DA
- 115 - 24 - 375DA
- 115 - 24 - 500DA
- 115 - 24 - 750DA

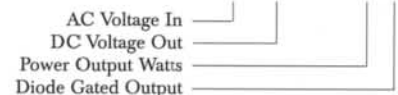
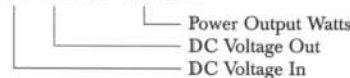

Cabinet Modules/Universal Chassis

() - () - X11() - 1000, - 2000, - 3000 or - 4000

Number of Windows High ————
Number of Windows Wide ————

SN = Flush-mounting
SNLR = Flush-mounting without Rear Cover
SNRR = Relay Rack-mounting

Alarm Modules

X11SN() () () () () ()

A ———— F
B ———— E
C ———— D

A. Designation:

- 1 = Single Point Alarm Module
- 2 = Dual Point Alarm Module
- 3 = Tri Point Alarm Module
- 4 = Quad Point Alarm Module

B. Sequence Type: (Other sequences available)

- MA = ISA M-1 or A-1
- F3AA = ISA F3A-1 or A-1
- ASLA = ISA A-4, 5, 6 or A-1

C. Field Contact Voltage:

- *0 = 24 Vdc
- 1 = 125 Vdc, not Opto-isolated
- 2 = 48 Vdc, not Opto-isolated
- 3 = 115 Vac or 125 Vdc, Opto-isolated
- 4 = 240 Vac or 250 Vdc, Opto-isolated
- 5 = 250 Vdc, not Opto-isolated
- 6 = 24 Vac or 24 Vdc, Opto-isolated
- 7 = 24 Vdc, Open Collector

* Standard Options

** CTA = Common Trouble Alarm

D. Special Options and CTA**:

- *00 = Operational Test, NNE CTA follows FC
- 04 = Operational Test, NNE CTA follows Alarm
- 09 = Lamp Test, NO CTA, Lamp Inhibit Input on F4, Dual Horn Selectable
- 10 = Lamp Test, NNE CTA follows FC
- 11 = Lamp Test, NNE CTA follows FC, Lamp Inhibit on F4, Dual Horn Selectable
- 12 = Operational Test, NNE CTA follows FC, Lamp Inhibit Input on F4, Dual Horn Selectable
- 13 = Option 09 and Four Point Lamp Holder on Non-4000 System
- 16 = Lamp and Operational Test PB, NNE CTA follows FC, First Out Reset and Reset PB
- 17 = Operational Test, NNE CTA follows FC, Dual Horn Selectable
- 18 = Operational Test, NNE CTA follows FC
- 19 = Operational Test, NNE CTA follows FC, FC Time Delay
- 20 = Lamp Test, NNE CTA follows FC, FC Time Delay
- 21 = Operational Test, NNE CTA follows FC, FC Time Delay, Lamp Inhibit Input on F4, Dual Horn Selectable

- 22 = Lamp Test, NNE CTA follows FC, FC Time Delay, Lamp Inhibit on F4, Dual Horn Selectable
- 23 = Operational Test, NNE CTA follows FC, Lamp Mimic Output on TOA-TOD

E. Auxiliary Relay Behavior:

- 0 = Switch Selectable Aux (Options 1-4)
- 1 = NE Aux follows FC
- *2 = NNE Aux follows FC
- 3 = NE Aux follows Alarm
- 4 = NNE Aux follows Alarm
- 5 = NE Aux follows Acknowledge
- 6 = NNE Aux follows Acknowledge
- 7 = NE Dual Aux follows FC
- 8 = NNE Dual Aux follows FC

F. Visual Display:

- *No Label = Standard Lamps
- D = Dual Lamps on 4000 System
- For LEDs Assign Color for Each Window:
- R = Red LED
- Y = Yellow LED
- G = Green LED
- L = Multicolored LEDs

Flasher (FL) Modules and Push-button/Flasher (FLPB) Modules

X11SN(FL) or (FLPB)() () () ()

(Applies to Push Button only) A ———— D or E
B ———— C

A. Push-button Designation:

- 2 = Flash with Test; Ack. PB
- 3A = Flash with Test; Ack. Reset PB
- 3B = Flash with Test; Silence Ack. PB
- 4 = Flash with Test; Ack. Reset and Silence PB

B. Systems Voltage:

- *0 = 24 Vdc

C. Board Behavior:

- *0 = Alarm Horn 1; Horn 2 Ringback 2 silenced by Reset PB; Reflash Output on Terminal F4; +V applied to Terminal F3 controls; Maintenance Relay
- 1 = Alarm Horns 1 and 2 assignable to Window; Both silenced by either Silence or Acknowledge PB
- 2 = Alarm Horn 1 with Auto Silence. Selectable DT 30 sec., 1, 5, or 10 min.; Alarm Horn 2 silenced by Reset PB

D. Push-button Special Options:

- 0 = Maintenance LED indicates Flasher Failure and +V applied to Terminal F3, e.g. Power Failure; Maintenance Relay HS
- 1 = Maintenance LED indicates Flasher Failure and +V applied to Terminal F3, e.g. Power Failure and CTA Activation; Maintenance Relay HS
- 2 = Maintenance LED indicates Flasher Failure and +V applied to Terminal F3 and Horn 2 Activation; Maintenance Relay HS
- *3 = Maintenance LED indicates Flasher Failure and +V applied to Terminal F3; Maintenance Relay GP
- 4 = Maintenance LED indicates Flasher Failure and +V applied to Terminal F3 and CTA Activation; Maintenance Relay GP
- 5 = Maintenance LED indicates Flasher Failure and +V applied to Terminal F3 and Horn 2 Activation; Maintenance Relay GP

E. Integral Flasher Special Options:

- 0 = No Auxiliary Relays, Maintenance Relay HS
- 1 = Channel A Auxiliary and Maintenance Relay HS
- 2 = Channels A and B Auxiliary and Maintenance Relay HS
- *3 = No Auxiliary Relays, Maintenance Relay GP
- 4 = Channel A Auxiliary and Maintenance Relay GP
- 5 = Channels A and B Auxiliary and Maintenance Relay GP

Note: The Maintenance Relay follows exclusively Flasher Failure and F3 input (+V).

* Standard Options

Auxiliary Contact Modules

X11SN() - AUX - ()

- 1 = Monalarm ————
- 2 = Dualarm ————
- 3 = Trialarm ————
- 4 = Quadalarm ————

Relay Type:

- GP = General Purpose Relay, 1 Amp. @ 24 Vdc, .5 Amp. @ 115 Vac
- HS = Hermetically Sealed Relay, 1 Amp. @ 24 Vdc, .5 Amp. @ 115 Vac

Note: Modules contain relays only. Universal Chassis allow addition of Auxiliary Contact Modules in the field.

THREE-YEAR WARRANTY

Ronan warrants equipment of its own manufacture to be free from defects in material and workmanship, under normal conditions of use and service, and will repair or replace any component found to be defective, on its return, transportation charges prepaid, within three (3) years of its original purchase. This warranty carries no liability, either expressed or implied, beyond our obligations to replace the unit which carries the warranty.

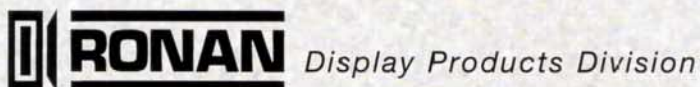

21200 Oxnard Street, Woodland Hills, CA 91367 U.S.A. • 800-327-6626 • Fax 818-992-6435
1 Tilley Rd., Crowther Industrial Estate, Washington, Tyne & Wear U.K., NE38-OEA • 191-416-1689 • Fax 191-416-5856
32 Bermondsey Rd., Toronto, Ontario, Canada M4B1Z5 • 416-752-0310 • Fax 416-752-8072

<http://www.ronan.com> E-Mail: ronan@ronan.com