

1. Identification

Energy and Flow Computer

Flow rate and energy calculator for liquids,
gases and water steam
MID approval no. DE-08-MI004-PTB004

E-DB-1000-700-01
Date of release 04.01.08

2. Area of Application

- Billing meter for district and local heat
- System monitoring in energy plants
- For heat/cold production in the middle and upper performance range
- For greater measuring accuracy and reliability requirements

ERW 700 calculation unit



Special features

- Suitable for gas, liquids (thermo-oil, glycol, etc), steam and water
- Can be combined with all conventional volume sensors (differential pressure, vortex, turbine, dynamic pressure, cross probe, ultrasonic, MID, coriolis)
- High-precision process calculation of density, enthalpy and compressibility based on equations or extensive database
- 2 independent 24 Bit AD converters for resistance (temperature) and current input, calculation speed 10 re-evaluations per second
- Compensation input for density signal
- Logger functions for 2 fixed dates, up to 30 monthly values, up to 800 periodic memory, 100 error memory, 100 parameter memory and min/max memory entries (31 days, 12 months)
- Parameterization and operation via PC software and/or manually via a keyboard
- Separate LC display (e.g. for switch cabinet door installation)
- Extensive modular extensions for inputs and outputs
- Various special functions, such as condensate measurement, bi-directional measurement, tariff or fault counters, etc.
- Large backlit graphical display, flexible configuration

Description

ERW 700 uses input data such as flow (differential pressure), pressure, temperature and density to calculate the volume, standard volume and mass of liquids, gases and steam.

Calculations

- Volumetric flow rate
- Standard volumetric flow rate
- Mass flow rate
- Heat flow/Cold flow

Counters

- Operating volume
- Standard volume
- Mass
- Heat quantity/Cold quantity
- Tariff counter, fault counter
- Balance counter, Energy difference

Inputs

- Current 0/4-20mA, incl. measuring transducer supply
- Frequency
- Pulse
- Temperature Pt100/500/1000 in 4-wire system passive or active.

Outputs

- Current 0/4-20mA
- Pulse
- Digital (Mbus, Modbus)
- Auxiliary power

Calculation methods

Liquids

- Density determination via algorithms and tables
- Heat capacity via algorithms and tables

Water/ Steam

Calculation standard IAP WS IF-97 (water steam table)

Gases

- Ideal gas law
- Flow correction considering temperature, pressure and compressibility
- Redlich-Kwong
- GERG 88

3. Principle of Operation and System Design

Liquids

Energy, volume (mass), flow rate, power

Calculation of the heat quantity and flow quantity transmitted to a heating or cooling system by a flow of liquid or which is absorbed by a flow of liquid. The heat quantity is calculated on the basis of the flow rate and the temperature difference between the supply and return.

Bi-directional measurements, such as charging/discharging of heat accumulators, and multiple-tariff measurements are also possible.

Furthermore, there is an input for direct density measurement of changing mixing ratios, e.g. for a water/glycol mix.

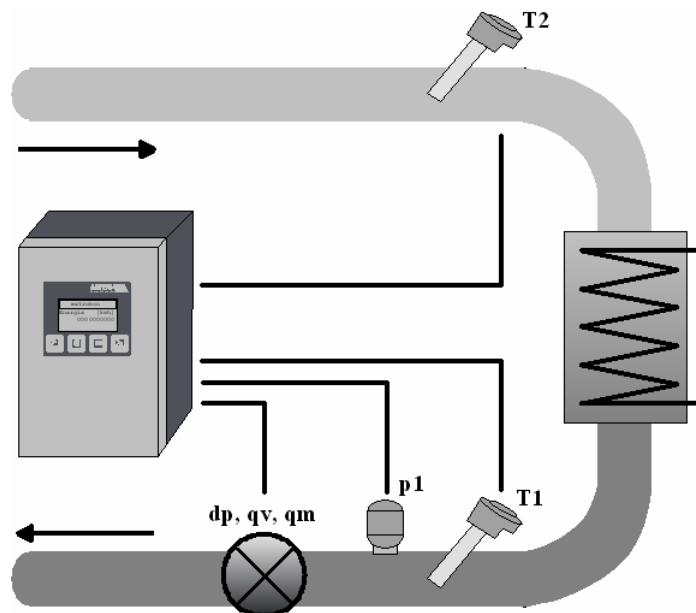

Heat quantity calculation using the flow and temperature difference input data. Volume sensor optionally assembled in supply or return line.

Steam

Energy, mass (volume), flow rate, power

Calculation of the heat quantity/flow quantity as a function of the steam flow, steam pressure and steam temperature process data.

Overheated steam calculation occurs in a pressure and temperature-compensated manner. Saturated steam calculation takes place in either a pressure- or temperature-guided manner. Numerous special functions, such as bi-directional measurements or multiple-tariff measurements are possible.

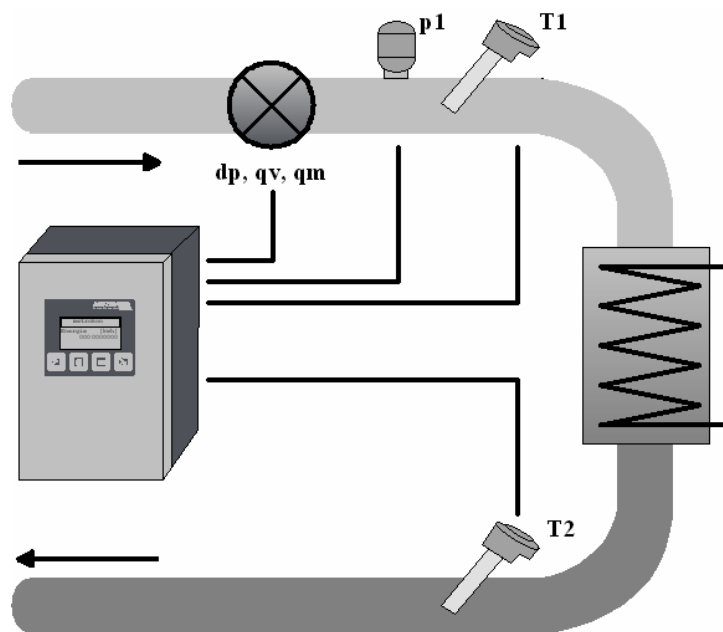

Calculation of the flow quantity/heat quantity in a sealed steam system using the flow, pressure and temperature input data.

Gas / Air

Energy, standard volume (mass), flow rate, power

Calculation of the gas volume flow and the gas mass as a function of the gas flow, gas pressure and gas temperature process data.

The heat quantity can also be determined. Furthermore, there is an input for direct density measurement, e.g. of changing mixing ratios.

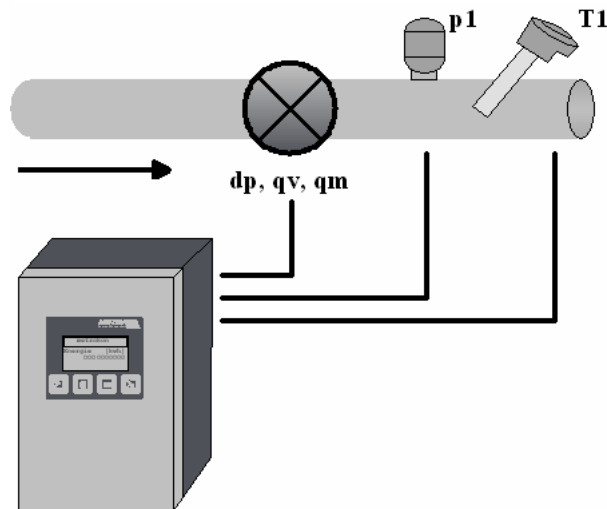

Calculation of the flow rate (power) as a function of the flow, pressure, temperature or density process data.

Measuring device design

The energy and flow computer ERW 700 is a state-of-the-art calculation unit. ERW 700 has a graphical display which allows users to view all the relevant measuring and calculation values. Using the menu guidance, it is possible to alter the configuration and parameters via the respective keys. Optional input and output cards are available to enhance device functioning.

The energy and flow computer consists of the following components:

- Calculation unit with integrated inputs and outputs (basic module)
- LC display unit with 4 keys
- Input cards (optional)
- Output cards (optional)

Maintenance requirements

Special maintenance is not required

Calibrated devices must be recalibrated after 5 years

IT security

The computer is password protected.

4. Input

Measuring data / Measuring uncertainty

Electrical measured data:

Current, pulse, frequency, resistance, contact (status)

Physical measured data:

Temperature, pressure, differential pressure, volume (flow), mass (flow), density

Special feature:

2 independent 24 Bit AD converters for resistance (temperature) and current.

Measured data	Input parameter
Resistance	Model: PT 100, PT500, PT1000 4-wire measurement Overload protection: ± 24 V Measuring uncertainty T: 0.1% of MV ± 0.1 K Measuring uncertainty ΔT : 0.1% of MV ± 0.02 K Temperature influence T: 0.0025% / K Temperature influence ΔT : 0.0010% / K Resolution: 24 Bit Measuring rate: approx. 16/s Sensor break monitoring
Current	Measuring range: 0 ... 0.22 mA Overload protection: ± 24 V Error detection 3.6 mA according to Namur NE43 Measuring uncertainty: 0.01% of MV ± 0.001 mA Temperature influence: 0.0025% / K Resolution: 24 Bit Measuring rate: approx. 16 / s
Frequency Pulse Status	Frequency measurement: 0.1 Hz ... 15 kHz Metering: 0 ... 15 kHz Min. measuring time can be set: (0.1 s, 1 s, 2 s) Measuring uncertainty: 0.01% of MV Temperature influence: 0.0025% / K Resolution: 0.001% of MV Switchable hardware filter: Without, 50 Hz (for suppressing contact bounces) Active signals: Voltage Lo (Us approx. 2 V), Hi (Us approx. 9 V) Passive signals: O.C, relay, Namur

Input data (basic device)

2 x Pt 100 / 500 / 1000
 2 x 0/4 – 20 mA, 2 x measuring transducer supply
 2 x pulse / frequency

Expansion stage input data (basic device plus additional input card)

2 x Pt 100 / 500 / 1000
 4 x 0/4 – 20 mA, 4 x measuring transducer supply
 2 x pulse / frequency

5. Output

Measuring data / Measuring uncertainty

Current, pulse, switching output/status, measuring transducer supply

Output variable	Output parameter
Current	Range: 0 ... 0.22 mA, active Max. load: > 500 Ω (U0 approx. 12V) Galvanic isolation among each other and to the basic device Error signals: 3.5 mA and 22 mA according to NAMUR NE43 Accuracy: 0.02% of MV ± 0.002 mA Temperature influence: 0.005% / K Resolution: 16 Bit
Pulse / Status	Type: Open collector, passive, galvanically isolated Frequency range: 0 ... 100 Hz Min. pulse width: 5 ms 500 ms Overload protection: ± 24 V Internal resistance 70 Ω Residual voltage < 1.2 V I _{max} : 20 mA U _{max} : 24 V

Number: (basic device)

2 x 0/4 – 20 mA
 3 x pulse / status
 1 x MBus
 1 x RS 232 Modbus
 1 x auxiliary power

Expansion stage 1: (basic device plus 1 additional output card)

4 x 0/4 – 20 mA
 5 x pulse / status
 1 x MBus
 1 x RS 232 Modbus
 1 x auxiliary power

Expansion stage 2: (basic device plus 2 additional output cards)

6 x 0/4 – 20 mA
 7 x pulse / status
 1 x MBus
 1 x RS 232 Modbus
 1 x auxiliary power

Reference conditions

Voltage supply: 230 VAC $\pm 10\%$, 50 Hz ± 0.5 Hz
Warm-up time: 10 min
Ambient temperature: 25 °C ± 5 °C
Humidity: 39% $\pm 10\%$ r. h.

Failure signal

- Error signal 3.5mA and 22mA in accordance with Namur NE43
- Error contact

Load

≥ 500 Ohm (U0 approx. 12V)

6. Operating Behaviour

- Accuracy class as heat meter in accordance with EN 1434-1
- Otherwise the behaviour depends on the medium and operating mode - typical 0.1%

7. Operating Conditions

7.1 Installation

Design

Wall installation in plastic housing

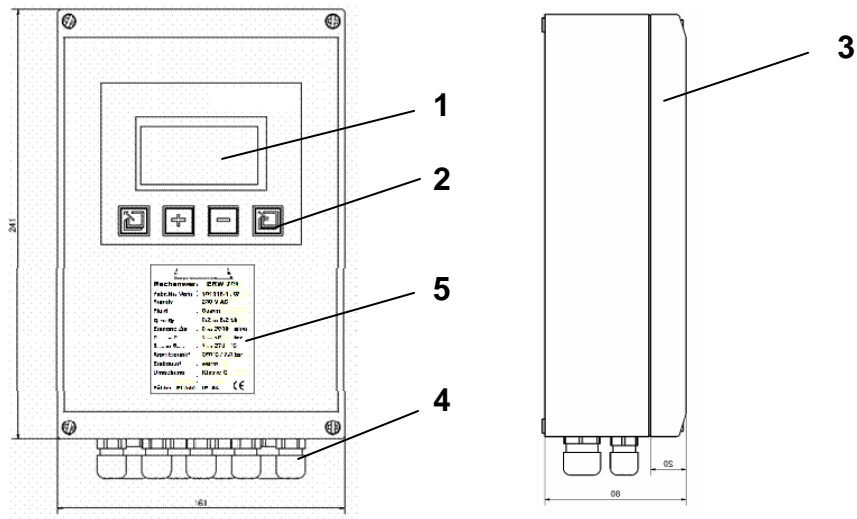

- 1 Display
- 2 Keyboard
- 3 Housing cover with display
- 4 Screwed cable gland
- 5 Type plate

Assembly

Various installations are possible:

- Housing with LCD for wall installation
- Housing without LCD for wall installation and separate LCD housing
- Housing for cabinet installation and separate installation of the LC-display in the cabinet door
- 19" plug-in unit design (in preparation)

Wall installation:

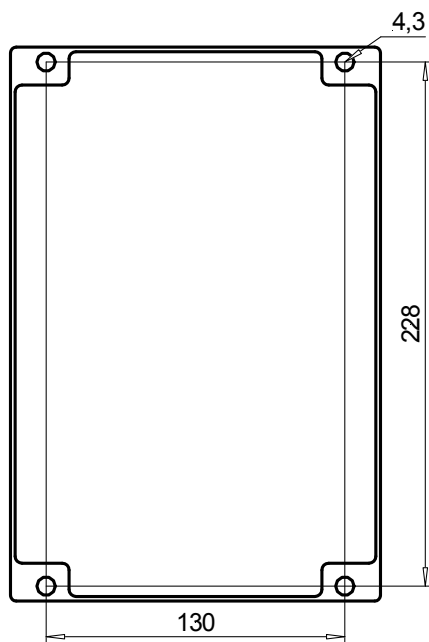

Control panel installation:

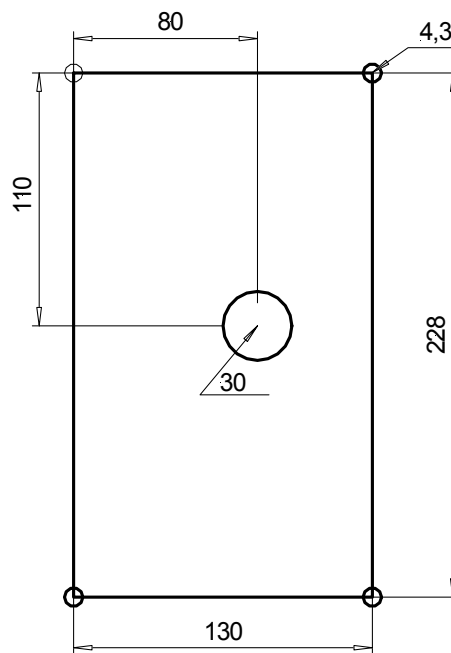

Climate class

C in accordance with EN 1434

Installation instructions

See ERW 700 operating instructions

Cable length

- For sensors in accordance with EC Directive 2004/22/EC Annex MI004 up to 10m
- For output signals and other installations up to 100m (depends on the laying and ambient conditions)

7.2 Ambient conditions

Ambient temperature range

0°C to 55°C, climate class C in accordance with EN 1434

Storage temperature

-30°C to 70°C

Electromagnetic compatibility

Interference emit:

EN 61326 Class A

Interference stability:

- Power failure: 20 ms, no influence
- Electromagnetic fields: 10 V/m (80 ... 2700 MHz) in accordance with EN 61000-4-3
- Electromagnetic fields: 30 V/m (800 ... 2,000 MHz) in accordance with EN 61000-4-3
- Conducted HF: 0.15 to 80 MHz, 10 V in accordance with EN 61000-4-6
- Electrostatic discharge: 4 kV contact / 8 kV indirect in accordance with EN 61000-4-2
- Burst (AC and DC supply): 4 kV in accordance with EN 61000-4-4
- Burst (signal): 1 kV / 2 kV in accordance with EN 61000-4-4
- Surge (AC and DC supply): 1 kV / 2 kV in accordance with EN 61000-4-5
- Surge (signal): 500 V / 1 kV in accordance with EN 61000-4-5
- EN1434-4 Class C
- EC Directive 2004/22/EC Class E2

7.3 Medium

Medium temperature range

Measuring ranges: -100°C to 600°C

PT100: -100°C to 600°C

PT500: -100°C to 500°C

PT1000: -100°C to 300°C

Medium pressure range

0-150 bar

Physical condition

Liquid, steam, gas

8. Constructive Design

Dimensions and weight

Model / Dimensions

1. Standard plastic housing

Front view:

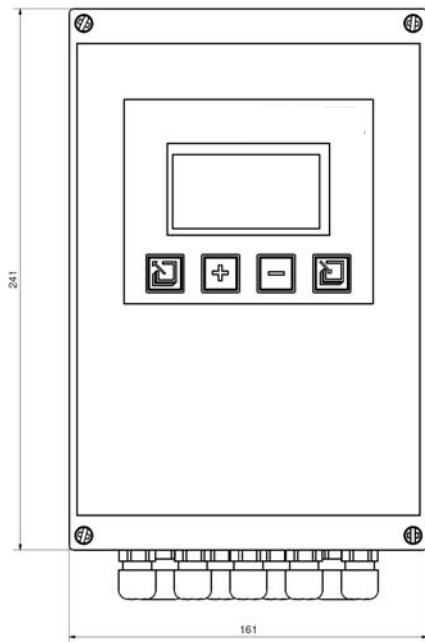

Side view:

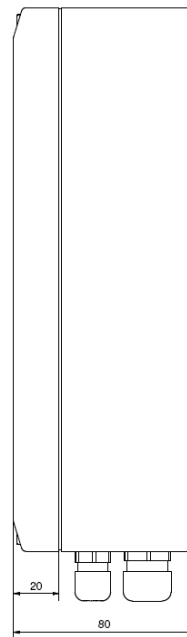

2. 19" plug-in unit design

Front view:

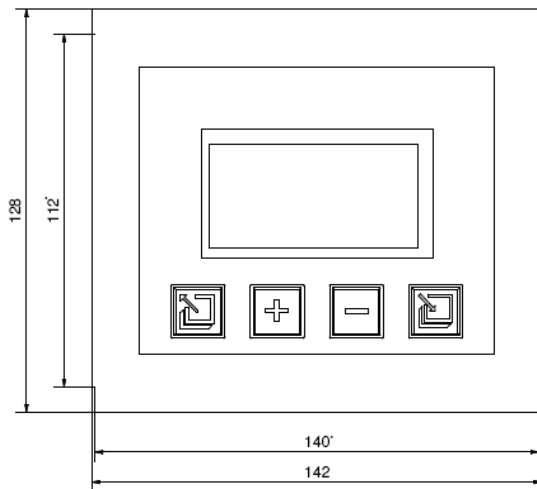

Side view

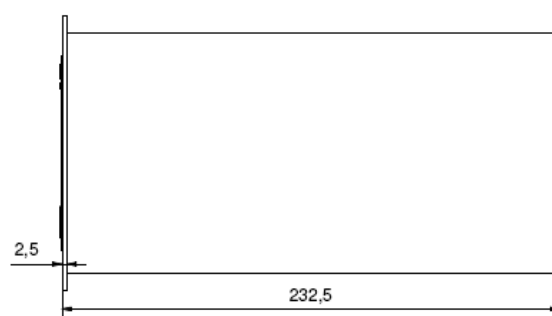

ERW 700 Data Sheet

Weight

Standard: Approx. 1 kg
19" plug-in unit design: Approx. 1.5 kg

Materials

Calculation unit: ABS -40°C to 80°C halogen-free
19" plug-in unit: Aluminium

Electrical connections

180 - 264 V AC
18 - 36 V DC

Power consumption

Between 5 and 30 W depending on the expansion stage

Degree of protection

IP 65 IEC 529 / EN 60529

9. Display and User Interface

- Large backlit graphical display, flexible configuration
- Can be installed separately, distance max. 5 m (switch cabinet door installation)
- Parameterization and operation via PC software and/or keyboard (4 keys)

10. Auxiliary Power

Measuring transducer supply and auxiliary power

Output data	Output parameter
Measuring transducer supply (MUS)	Voltage: 24 V DC Current: Max. 30 mA, short circuit proof
Auxiliary power	Voltage: 24 V DC Current: Max. 250 mA, short circuit proof

11. Certificates and Approvals

EC declaration of conformity
MID (EC Directive 2004/22/EC) approval no. DE-08-MI004-PTB004

12. Order Information / Tendering Text

Universal energy and flow computer

Energy and flow computer "autarkon" ERW 700
Housing made of impact-resistant plastic for wall or control panel installation

Medium: _____
Operating mode: Energy/Flow: _____
Operating temperature: _____ °C
Operating pressure: _____ bar
Place of installation: _____
Supply/Return: _____
Volume/Mass input: _____
Model: _____
Compact: _____
Separate display: _____

LC multifunctional display, large backlit graphical display, flexible configuration for all relevant values

Logger functions for fixed date, monthly values, periodic memory, error memory parameter memory and min/max. memory

No applications set

Inputs: 2 x 0/4-20mA freely programmable
 2 x temperature inputs for PT 100/500/1000 4-wire system, passive
 2 x pulse / frequency input, freely programmable

Outputs: 2 x 0/4-20mA galv. isolated, freely programmable
 3 x optocoupler output, galv. isolated, freely programmable
 1 x M-Bus
 1 x RS 232 (Modbus)
 1 x auxiliary power 24 VDC
 2 x measuring transducer supply 24 V DC

Degree of protection: IP 65 in accordance with EN 60529

Ambient temperature: 0 - 55°C

Auxiliary power: 230V 50/60Hz, 24 V DC

Additional equipment:

Output card 1:

2 x analogue output 0/4-20mA, galv. isolated, freely programmable
2 x optocoupler output, galv. isolated, freely programmable

Output card 2:

2 x analogue output 0/4-20mA, galv. isolated, freely programmable
2 x optocoupler output, galv. isolated, freely programmable

Input card:

2 x analogue input 0/4-20mA freely programmable
2 x measuring transducer supply 24 V DC

ERW 700 Data Sheet

- Separate display for wall/control panel installation incl. 5 m connection cable
- Configuration software with PC interface cable for setting and documenting
- Customised configuration of the calculation unit
- Calibration as heat meter in accordance with MID (certificate)
- 19" plug-in unit made of aluminium (on request)
- Density input (in conjunction with density sensor for changing mixing ratios)

Software versions

- Bi-directional measurement with 2 additional counters
- Flow and heat quantity determination with condensate measurement and additional counters
- Heat/Cold changeover with 2 additional counters
- Limit value dependent tariff changeover with additional counters
- Special calibration for water-glycol mixtures, thermo-oil and other liquid mixtures with constant mixture ratio
- Input of C value, including linearization

13. Documentation

ERW 700 E-BA-5000-001-01